

LYNX PROFESSIONAL SERIES



UPDATED JANUARY 2024

HOMEA
PREMIUM

HOMEA

www.homea.mx

Email: ventas@homea.mx

Whatsapp: (442)258.0251

Tel: (442)216.3552

Lada sin Costo: 01(800)701.2121

LYNX

LIVE THE LYNX LIFE



LYNX LIFE	4
PROFESSIONAL SERIES	7
PROFESSIONAL FEATURES	8
LYNX CHEF'S PANEL	12
BUILT-IN GRILLS	14
FREESTANDING GRILLS	22
LYNX SPECIALTY COOKING	30
NAPOLI OUTDOOR OVEN™	32
ASADO COOKTOP	36
PROFESSIONAL BURNERS	40
WARMING DRAWERS	44
LYNX OUTDOOR KITCHENS	46
DESIGN CENTER	48
REFRIGERATION	50
VENTANA STORAGE COLLECTION	54
CLASSIC STORAGE COLLECTION	60
SINKS AND COCKTAIL SOLUTIONS	66
OUTDOOR HEATING	68
ACCESSORIES	70
PROFESSIONAL SPECIFICATIONS	74
WARRANTY	84

Lynx is committed to providing the best customer experience and product service possible. We have a dedicated team of highly trained professionals to answer your needs Monday–Friday during regular business hours.

For technical questions or service please
e-mail: service@lynxgrills.com
or call: 888.289.5969



LYNX

LIVE THE LYNX LIFE

MIDDLEBY.COM.MX



It's more than a grill, it's a state of mind. Born in Southern California, and rooted in a mix of stunning geography, idyllic weather, stylish people, and healthy, adventurous cuisine. It's an environment that drives innovation, comfort, and ingenuity. A place that is the envy of a nation cursed to conform to the seasons.

It's only natural that a superior outdoor suite of cooking equipment would come from here. Where better to craft the perfect luxury lifestyle product?

More than just a place, more than just a grill, its a way of life.

We invite you to live the Lynx Life.





LYNX PROFESSIONAL SERIES

The Professional Life is all about the details. It's luxurious living, and hand craftsmanship. It's foods prepared on the finest materials money can buy. Crafted by those who know their art. New technology designed and implemented by edgy thinkers, determined to elevate the culinary arts, no matter what's being prepared - from traditional BBQ to luxurious recipes.

The Lynx Professional isn't for show, it's a work of art. It's not about glamour, it's about cooking on a superior machine. One so well engineered and built, that it can seamlessly blend into an elegant outdoor room, but perform on par with its professional restaurant cousins.

A better life deserves a better grade of grill.

MIDDLEBY.COM.MX

LYNX PROFESSIONAL SERIES FEATURES

Our unrelenting attention to detail and our passion for innovation have fostered the stunning features that define the Lynx Professional Series.

These features begin with meticulous hand-crafted excellence, and they culminate in powerful capabilities that give you precision control. They give you the power to perfectly finish a baseball cut of top sirloin, smoke a swordfish steak, slowly brown a rotisserie leg of lamb, or even char a leaf of lettuce without wilting the edge.

If you are accustomed to tasting the best that the world has to offer, then you have been waiting for the Lynx Professional Series.

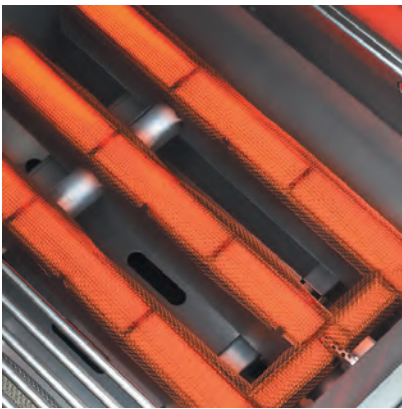

TRIDENT™ INFRARED BURNER

When you have refined taste, you recognize perfect control. You relish performance that you can restrain—and call upon at your own will. Traditional grill burners are hard to control, because they cook by heating the air around your food. That takes time to change.

A Lynx Trident™ Infrared Burner directly heats the grate beneath your food with 23,000 BTUs of intensive heat. With temperature control that's instantaneous, ranging from 300°-1000°, it's the method employed by the world's leading chefs, and now it's in your grill. This kind of control can cook a perfect salad—putting a delicious char on romaine lettuce without wilting a leaf. Now, just imagine what it does for tenderloin or tilapia.

Feel the precision of perfect control.



CERAMIC BURNER

The finest cuisine is original and inspired. But it's never unpredictable. Traditional grill burners are inconsistent, because their metal changes as they cook. They suffer when extreme heat expands and contracts the metal, loosening bonds over time. Performance weakens as food residue clogs ports, or corrosive outdoor weather degrades the material.

The Lynx ceramic burner is made from cordierite ceramic, a material chosen for kilns and commercial ovens because of the temperatures that it endures. We tested these burners relentlessly, igniting them thousands of times, even when encrusted with sauce or encased with ice.

When we place these radiant gems at the heart of your Lynx Grill, we harness them to controls that let you precisely tune a power you haven't felt before.



SEAMLESS WELDED CONSTRUCTION

The Lynx workshop in California is a study in skill, a lesson in craft.

A welder pauses to focus on an unwelded seam... then, with one swift and steady stroke, he sweeps his torch across the seam—like painting a perfect line—and an unbroken edge emerges.

It's over in a second, and that's how it has to be done. We do not use mechanical fasteners. We form every sheet of metal into a solitary, seamless body of shimmering steel, free of gaps and seams where moisture could collect. Hand-tooled, precision welded, and highly polished by the skilled specialists in our shop, each and every grill is inspected before it leaves our floor. We examine details on every side, step back, and check reflections in every light, to ensure that your grill embodies Lynx—finished with invisible welds and hand-polished edges that shine like mirrors.

LYNX PROFESSIONAL SERIES FEATURES



HEAT STABILIZING DESIGN

Nature's tempests can arise in even in the most scenic places. Mountain resorts, beachside villas, and even inland estates are sometimes subject to great and turbulent gusts of wind.

Lynx has found that these gusts can affect typical grills, entering through the vents. They create swirls of temperature change beneath the grill's hood, and subject tender cuisine to uneven cooking. Our research led us to develop an exclusive wind-deflecting fin along the back of our hoods.

It's how we ensure that people in spectacular places can always create spectacular food.



HOT SURFACE IGNITION

Everything you cook with a Lynx can have a perfect finish.

And it can have a perfect start.

Lynx Hot Surface Ignition lights your grill with the push of a knob. It is weather-tested electronic ignition that simply works, every time, vaporizing the uncertainty and inconvenience of lighting traditional gas grills.

The Lynx Life deserves a perfect beginning.

It's easy, from start to finish.



CERAMIC RADIANT BRIQUETTES

Perfect outdoor cooking begins with even heat.

Charcoal briquettes can form a steady glow of heat beneath your food—but traditional gas grill burners can create irregular hot spots, forcing you to continually flip and move your food to achieve an even finish.

With Lynx Ceramic Briquettes, your gas grill emanates a perfectly even heat across the base of your grill.

For your convenience, in five minutes, you can cleanse the briquettes by reversing the tray and raising the heat.



ROTISSERIE SYSTEM

A rotisserie unlocks a new realm of food. There is no better way to carefully and evenly cook generous meats like whole chickens and roasts, or baskets of vegetables, chicken wings, and sides.

The Lynx Rotisserie has a dedicated burner, selectable positions, and selectable speeds to ensure you have a full range of options. With the optional Lynx Rotisserie Basket, you can carefully cook smaller dishes and sides while preparing a main—you can even roast your own coffee beans. It's simply mesmerizing to watch the Lynx rotisserie steadily turn, summoning mouth-watering scents as it elicits a crisp exterior and succulent interior for lemon rotisserie chicken, red wine leg of lamb, a honey glazed ham, or a bourbon rotisserie pork roast.

The image lingers for a while, but the aroma is unforgettable.

LYNX PROFESSIONAL SERIES FEATURES



SMOKER BOX

When a meal has been cooked with seasoned wood smoke, it has a flavor that's like nothing else.

It's something that must be experienced—a nuance of hickory, mesquite, pecan—the tastes are legendary, the aromas unmistakable.

That's why we provide our stainless steel smoker box, and why we make sure it's easy to use.

You don't always need to use it, but you always need to have the choice.



INTEGRATED ILLUMINATION

The Lynx Life continues all day long, all year round. And there's a mystical air that arises, just as the sun starts to set and the evening arrives. It's a beautiful time to grill... if you can.

Every Lynx grill incorporates elegant blue illumination emanating from each knob with a calm blue light. As you lift the lid, intuitive halogen illumination shows you exactly how your food is looking.

So, just check in on your food.

Then, get back to basking in the sundown grill aroma. It seems to steal an amber essence from the last of the sun.



EXPANSIVE GRILLING SURFACE

The Lynx Life is expansive and deep. It has space to move and relax, always has room for more, and never feels limited or confined.

So, we built our grills with more space in mind.

Our expansive grilling surfaces provide greater depth, extending to more than 20 inches deep on most models.

You might not need it all. It just feels good to have it.

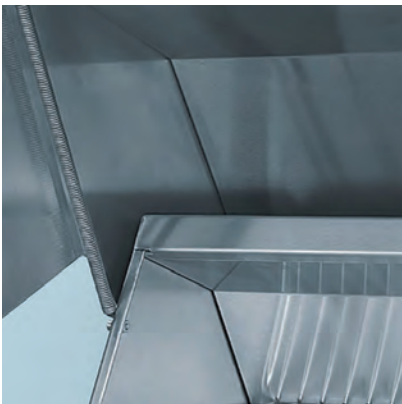

LYNX HOOD ASSIST

Solid stainless steel gives our grills a sense of substance.

They feel firm at every touch, with a sound and an aura of permanence.

But you can lift the hoods with just a finger—each one is centrally balanced, and has a heat-treated assist system that makes it surprisingly weightless to open and close.

You'll probably do it twice—just to feel it again.

Go ahead. Everyone does.

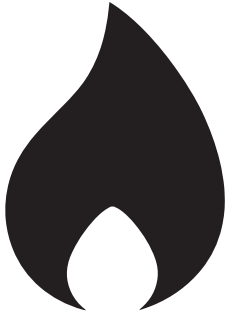

FLAMETRAK™ SAFETY SYSTEM

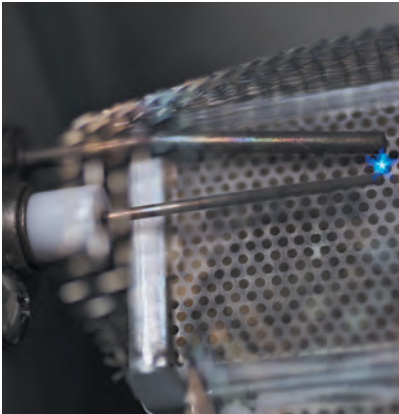

IGNITION SYSTEM

The Flametrak™ safety system uses a sensor that can tell if a burner's flame is out. The sensor tries to relight the burner, then shuts off the burner's gas if there is no flame for 13 seconds. With a sensor on each burner, the Flametrak system helps provide grill safety whether a flame fails to ignite or a flame blows out.

NOTIFICATIONS

The Flametrak system tells grill users when it has taken action. The Flametrak indicator just above each burner knob lets grill users check the flame's status at a glance, rather than having to open the grill and look for a flame beneath the grates.

THE SCIENCE BEHIND THE SAFETY

The Flametrak system is based on flame rectification. Flame rectification is the effect where electrical current changes from alternating current (AC) to direct current (DC) as it passes through a flame. If the current does not change to DC, then the Flametrak switch knows the flame is out—and it relights or shuts off the gas. Flame rectification is proven technology that many water heaters and other devices use to confirm the presence of a flame.

THE LYNX ALL TRIDENT GRILL

In 2018, the Lynx All Trident Grill is the first grill to feature the Flametrak safety system. It sets the industry standard in performance and safety. The Flametrak safety system is patent pending.



FLAMETRAK INDICATOR ERROR



LYNX PROFESSIONAL BUILT-IN GRILLS

A built-in Lynx Professional grill is a crowning jewel, waiting to be set at the center of your outdoor kitchen.

LYNX 54" PROFESSIONAL BUILT-IN GRILL



OPEN VIEW

PRODUCT OVERVIEW

- Precise power—one Trident™ Infrared Burner and three Cast Ceramic Burners combining to provide up to 98,000 BTU
- Generous capacity—1,555 square inches of cooking surface (1,110 primary, 445 secondary)
- Slow-cooking excellence—with a dual-position rotisserie internally powered by a heavy-duty three-speed motor, and a rear infrared burner delivering up to 14,000 BTU
- Indulgent extra—premium smoker box included
- Beautiful illumination—luminous blue-lit control knobs
- Steady performance—heat-stabilizing design
- Reliable speed—Hot Surface Ignition system lights burners quickly and safely
- Perfect clarity—dual halogen grill surface lights
- Quick visibility—temperature gauge
- Easy opening—Lynx Hood Assist
- Smooth movement—fluid rotation handle
- Premier platform—stainless steel grilling grates
- Steadfast durability—heavy-duty welded construction eliminates gaps where grease can collect
- Open options—available in Natural Gas and LP

MODEL	DESCRIPTION	USD
L54TR	54" Built-In Grill - 1 Trident Burner with Rotisserie	\$ 15,365
LIJ54	Insulating Jacket for 54" Built-In-Grill	\$ 1,622
CC54	54" Carbon Fiber Vinyl Cover (Built-In)	\$ 465

NOTE: Must specify gas type—NG for Natural Gas or LP for Propane

LYNX 42" PROFESSIONAL BUILT-IN GRILL



OPEN VIEW

PRODUCT OVERVIEW

- Diverse choices—available in three different burner configurations
- Generous capacity—1,200 square inches of cooking surface (855 primary, 345 secondary)
- Slow-cooking excellence—with a dual-position rotisserie internally powered by a heavy-duty three-speed motor, and a rear infrared burner delivering up to 16,000 BTU
- Indulgent extra—premium smoker box included
- Beautiful illumination—luminous blue-lit control knobs
- Steady performance—heat-stabilizing design
- Reliable speed—Hot Surface Ignition system lights burners quickly and safely
- Perfect clarity—dual halogen grill surface lights
- Quick visibility—temperature gauge
- Easy opening—Lynx Hood Assist
- Smooth movement—fluid rotation handle
- Premier platform—stainless steel grilling grates
- Steadfast durability—heavy-duty welded construction eliminates gaps where grease can collect
- Open options—available in Natural Gas and LP

MODEL	DESCRIPTION	USD
L42R-3	42" Built-In Grill with Rotisserie	\$ 12,765
L42TR	42" Built-In Grill - 1 Trident IR Burner with Rotisserie	\$ 12,765
L42ATR	42" Built-In Grill - All Trident IR Burner with Rotisserie	\$ 12,765
LIJ42	Insulating Jacket for 42" Built-In Grill	\$ 1,547
CC42	42" Carbon Fiber Vinyl Cover (Built-In)	\$ 373

NOTE: Must specify gas type—NG for Natural Gas or LP for Propane

LYNX 36" PROFESSIONAL BUILT-IN GRILL



OPEN VIEW

 **FLAMETRAK™**
SAFETY SYSTEM
AVAILABLE ON THE LF36ATR MODEL

PRODUCT OVERVIEW

- Diverse choices—available in three different burner configurations
- Ample capacity—935 square inches of cooking surface (640 primary, 295 secondary)
- Slow-cooking excellence—with a dual-position rotisserie internally powered by a heavy-duty three-speed motor, and a rear infrared burner delivering up to 14,000 BTU
- Reliable speed—Hot Surface Ignition system lights burners quickly and safely *(Note: Grill with Flametrak™ uses a high speed Spark Ignition rather than Hot Surface Ignition)*
- Unprecedented safety—FLAMETRAK™ safety system shuts off the gas if the flame goes out *(available only on the LF36ATR Model)*.
- Indulgent extra—premium smoker box included
- Beautiful illumination—luminous blue-lit control knobs
- Steady performance—heat-stabilizing design
- Perfect clarity—dual halogen grill surface lights
- Quick visibility—temperature gauge
- Easy opening—Lynx Hood Assist
- Smooth movement—fluid rotation handle
- Premier platform—stainless steel grilling grates
- Steadfast durability—heavy-duty welded construction eliminates gaps where grease can collect
- Open options—available in Natural Gas and LP

MODEL	DESCRIPTION	USD
L36R-3	36" Built-In Grill with Rotisserie	\$ 11,519
L36TR	36" Built-In Grill - 1 Trident IR Burner with Rotisserie	\$ 11,519
L36ATR	36" Built-In Grill - All Trident IR Burner with Rotisserie	\$ 11,519
LF36ATR	36" Built-In All-Trident Grill with Rotisserie and Flametrak	\$ 12,720
LJ36	Insulated Jacket for 36" Built-In-Grill	\$ 1,516
CC36	36" Carbon Fiber Vinyl Cover (Built-In)	\$ 359

NOTE: Must specify gas type—NG for Natural Gas or LP for Propane

LYNX 30" PROFESSIONAL BUILT-IN GRILL



OPEN VIEW

PRODUCT OVERVIEW

- Diverse choices—available in three different burner configurations
- Ample capacity—840 square inches of cooking surface (600 primary, 240 secondary)
- Slow-cooking excellence—with a dual-position rotisserie internally powered by a heavy-duty three-speed motor, and a rear infrared burner delivering up to 14,000 BTU
- Indulgent extra—premium smoker box included
- Beautiful illumination—luminous blue-lit control knobs
- Steady performance—heat-stabilizing design
- Reliable speed—Hot Surface Ignition system lights burners quickly and safely
- Perfect clarity—halogen grill surface light
- Quick visibility—temperature gauge
- Easy opening—Lynx Hood Assist
- Smooth movement—fluid rotation handle
- Premier platform—stainless steel grilling grates
- Steadfast durability—heavy-duty welded construction eliminates gaps where grease can collect
- Open options—available in Natural Gas and LP

MODEL	DESCRIPTION	USD
L30R-3	30" Built-In Grill with Rotisserie	\$ 8,184
L30TR	30" Built-In Grill - 1 Trident IR Burner with Rotisserie	\$ 8,184
L30ATR	30" Built-In Grill - All Trident IR Burner with Rotisserie	\$ 8,184
LIJ30	Insulated Jacket for 30" Built-In-Grill	\$ 1,441
CC30	30" Carbon Fiber Vinyl Cover (Built-In)	\$ 314

NOTE: Must specify gas type—NG for Natural Gas or LP for Propane



BUILT-IN INSULATED JACKET

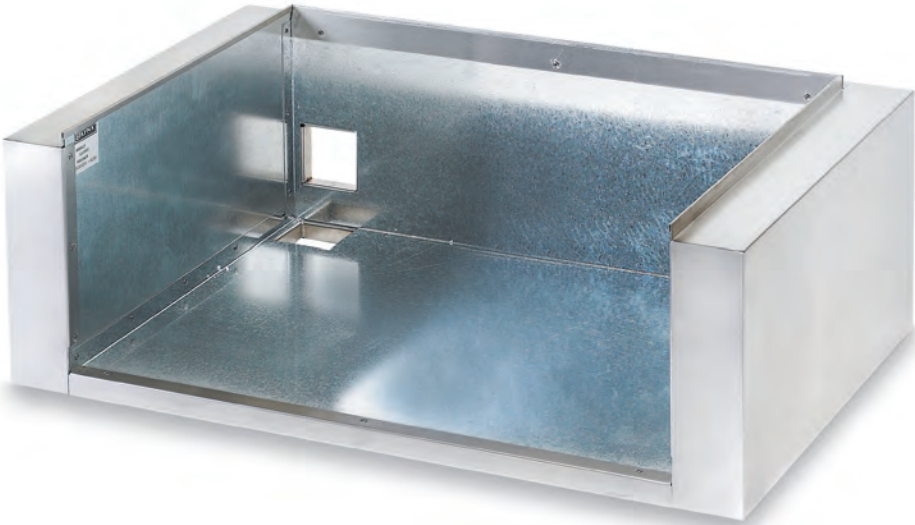

MODELS
LIJ30 / LIJ36 / LIJ42 / LIJ54

INSULATED JACKET

- Secure assurance—required for grills installed in islands with combustible materials
- Steadfast durability—heavy-duty welded construction

MODEL	DESCRIPTION	USD
LIJ30	Insulated Jacket for 30" Grill and Asado Grill	\$ 1,441
LIJ36	Insulated Jacket for 36" Grill	\$ 1,516
LIJ42	Insulated Jacket for 42" Grill	\$ 1,547
LIJ54	Insulated Jacket for 54" Grill	\$ 1,622

BUILT-IN COVERS



MODELS

CC30 / CC36 / CC42 / CC54

CARBON FIBER VINYL GRILL COVERS (BUILT-IN)

- Perfect protection—a custom tailored fit
- Lasting resilience—tough textured vinyl
- Secure durability—pocket seams for lasting quality and a flexible cord for a close fit
- Quick placement—nylon finger loops help pull and secure the cover in place
- Tasteful elegance—deep embossed Lynx logo
- Delicate touch—felt lining protects stainless steel finishes
- Intelligent design—rear vent helps to expel moisture

MODEL	DESCRIPTION	USD
CC30	30" Carbon Fiber Vinyl Cover (Built-in)	\$ 314
CC36	36" Carbon Fiber Vinyl Cover (Built-in)	\$ 359
CC42	42" Carbon Fiber Vinyl Cover (Built-in)	\$ 373
CC54	54" Carbon Fiber Vinyl Cover (Built-in)	\$ 465



LYNX PROFESSIONAL FREESTANDING GRILLS

A freestanding Lynx Professional grill gives you a luxury grilling experience that moves you—and moves with you.

LYNX 54" PROFESSIONAL FREESTANDING GRILL



PRODUCT OVERVIEW

- Precise power—one Trident™ Infrared Burner and three Cast Ceramic Burners combining to provide up to 98,000 BTU
- Generous capacity—1,555 square inches of cooking surface (1,110 primary, 445 secondary)
- Slow-cooking excellence—with a dual-position rotisserie internally powered by a heavy-duty three-speed motor, and a rear infrared burner delivering up to 14,000 BTU
- Indulgent extra—premium smoker box included
- Beautiful illumination—luminous blue-lit control knobs
- Steady performance—heat-stabilizing design
- Reliable speed—Hot Surface Ignition system lights burners quickly and safely
- Perfect clarity—dual halogen grill surface lights
- Quick visibility—temperature gauge
- Easy opening—Lynx Hood Assist
- Smooth movement—fluid rotation handle
- Premier platform—stainless steel grilling grates
- Steadfast durability—heavy-duty welded construction eliminates gaps where grease can collect
- Open options—available in Natural Gas and LP

MODEL	DESCRIPTION	USD
L54TRF	54" Freestanding Grill - 1 Trident IR Burner with Rotisserie	\$ 19,240
LCB2-3	Cart Mounted Double Side Burner	\$ 2,913
LSTLP	Sliding Tank Tray, cart units 30", 42" and 54" only	\$ 448
CC54F	54" All Grill Carbon Fiber Vinyl Cover (Freestanding)	\$ 629
CC54FCB	54" All Grill Carbon Fiber Vinyl Cover (Freestanding with Side Burner)	\$ 765

NOTE: Must specify gas type—NG for Natural Gas or LP for Propane

LYNX 42" PROFESSIONAL FREESTANDING GRILL



PRODUCT OVERVIEW

- Diverse choices—available in two different burner configurations
- Generous capacity—1,200 square inches of cooking surface (855 primary, 345 secondary)
- Slow-cooking excellence—with a dual-position rotisserie internally powered by a heavy-duty three-speed motor, and a rear infrared burner delivering up to 16,000 BTU
- Indulgent extra—premium smoker box included
- Beautiful illumination—luminous blue-lit control knobs
- Steady performance—heat-stabilizing design
- Reliable speed—Hot Surface Ignition system lights burners quickly and safely
- Perfect clarity—dual halogen grill surface lights
- Quick visibility—temperature gauge
- Easy opening—Lynx Hood Assist
- Smooth movement—fluid rotation handle
- Premier platform—stainless steel grilling grates
- Steadfast durability—heavy-duty welded construction eliminates gaps where grease can collect
- Open options—available in Natural Gas and LP

MODEL	DESCRIPTION	USD
L42TRF	42" Freestanding Grill - 1 Trident IR Burner with Rotisserie	\$ 15,394
L42ATRF	42" Freestanding Grill - All Trident IR Burner with Rotisserie	\$ 15,394
LCB2-3	Cart Mounted Double Side Burner	\$ 2,913
LSTLP	Sliding Tank Tray, cart units 30", 42" and 54" only	\$ 448
CC42F	42" Carbon Fiber Vinyl Cover (Freestanding)	\$ 523
CC42FCB	42" Carbon Fiber Vinyl Cover (Freestanding with Side Burner)	\$ 570

NOTE: Must specify gas type—NG for Natural Gas or LP for Propane

LYNX 36" PROFESSIONAL FREESTANDING GRILL



FLAMETRAK™
 SAFETY SYSTEM
 AVAILABLE ON THE LF36ATRF MODEL

PRODUCT OVERVIEW

- Diverse choices—available in three different models
- Ample capacity—935 square inches of cooking surface (640 primary, 295 secondary)
- Slow-cooking excellence—with a dual-position rotisserie internally powered by a heavy-duty three-speed motor, and a rear infrared burner delivering up to 14,000 BTU
- Reliable speed—Hot Surface Ignition system lights burners quickly and safely *(Note: Grill with Flametrak™ uses a high speed Spark Ignition rather than Hot Surface Ignition)*
- Unprecedented safety—FLAMETRAK™ safety system shuts off the gas if the flame goes out *(available only on the LF36ATRF Model)*.
- Indulgent extra—premium smoker box included
- Beautiful illumination—luminous blue-lit control knobs
- Steady performance—heat-stabilizing design
- Perfect clarity—dual halogen grill surface lights
- Quick visibility—temperature gauge
- Easy opening—Lynx Hood Assist
- Smooth movement—fluid rotation handle
- Premier platform—stainless steel grilling grates
- Steadfast durability—heavy-duty welded construction eliminates gaps where grease can collect
- Open options—available in Natural Gas and LP

MODEL	DESCRIPTION	USD
L36TRF	36" Freestanding Grill - 1 Trident IR Burner with Rotisserie	\$ 14,208
L36ATRF	36" Freestanding Grill - All Trident IR Burner with Rotisserie	\$ 14,208
LF36ATRF	36" Freestanding All-Trident Grill with Rotisserie and Flametrak	\$ 15,365
LCB2-3	Cart Mounted Double Side Burner	\$ 2,913
CC36F	36" Carbon Fiber Vinyl Cover (Freestanding)	\$ 479
CC36FCB	36" Carbon Fiber Vinyl Cover (Freestanding with Side Burner)	\$ 540

NOTE: Must specify gas type—NG for Natural Gas or LP for Propane

LYNX 30" PROFESSIONAL FREESTANDING GRILL



PRODUCT OVERVIEW

- Diverse choices—available in two different burner configurations
- Ample capacity—840 square inches of cooking surface (600 primary, 240 secondary)
- Slow-cooking excellence—with a dual-position rotisserie internally powered by a heavy-duty three-speed motor, and a rear infrared burner delivering up to 14,000 BTU
- Indulgent extra—premium smoker box included
- Beautiful illumination—luminous blue-lit control knobs
- Steady performance—heat-stabilizing design
- Reliable speed—Hot Surface Ignition system lights burners quickly and safely
- Perfect clarity—halogen grill surface light
- Quick visibility—temperature gauge
- Easy opening—Lynx Hood Assist
- Smooth movement—fluid rotation handle
- Premier platform—stainless steel grilling grates
- Steadfast durability—heavy-duty welded construction eliminates gaps where grease can collect
- Open options—available in Natural Gas and LP

MODEL	DESCRIPTION	USD
L30TRF	30" Freestanding Grill - 1 Trident IR Burner with Rotisserie	\$ 9,460
L30ATRF	30" Freestanding Grill - All Trident IR Burner with Rotisserie	\$ 9,460
LCB2-3	Cart Mounted Double Side Burner	\$ 2,913
LSTLP	Sliding Tank Tray, cart units 30", 42" and 54" only	\$ 448
CC30F	30" Grill or Smoker Carbon Fiber Vinyl Cover (Freestanding)	\$ 465
CC30FCB	30" Carbon Fiber Vinyl Cover (Freestanding with Side Burner)	\$ 523

NOTE: Must specify gas type—NG for Natural Gas or LP for Propane

LYNX 30" PROFESSIONAL GRILL ON MOBILE KITCHEN CART



LYNX 30" PROFESSIONAL GRILL ON MOBILE KITCHEN CART
 SHOWN HERE: L30AG + L30CART. GRILL AND CART NEED TO BE ORDERED SEPARATELY
 (ASSEMBLY REQUIRED)

PRODUCT OVERVIEW

- Diverse choices—available in two different burner configurations
- Ample capacity—840 square inches of cooking surface (600 primary, 240 secondary)
- Slow-cooking excellence—with a dual-position rotisserie internally powered by a heavy-duty three-speed motor, and a rear infrared burner delivering up to 14,000 BTU
- Indulgent extra—premium smoker box included
- Beautiful illumination—luminous blue-lit control knobs
- Steady performance—heat-stabilizing design
- Reliable speed—Hot Surface Ignition system lights burners quickly and safely
- Perfect clarity—halogen grill surface light
- Quick visibility—temperature gauge
- Easy opening—Lynx Hood Assist
- Smooth movement—fluid rotation handle
- Premier platform—stainless steel grilling grates
- Steadfast durability—heavy-duty welded construction eliminates gaps where grease can collect
- Open options—available in Natural Gas and LP
- 30" Grill can be placed on the Mobile Kitchen Cart for extra space
- 54" wide cart with ample counterspace to set down food and tools
- Double storage drawers for storing utensils and grilling tools
- Large casters for easy and smooth movement

MODEL	DESCRIPTION	USD
L30R-3 + LMKC54	30" Grill with Rotisserie on Mobile Kitchen Cart	\$ 14,190
L30TR + LMKC54	30" Grill - 1 Trident IR with Rotisserie on Mobile Kitchen Cart	\$ 14,190
L30ATR + LMKC54	30" Grill - All Trident IR with Rotisserie on Mobile Kitchen Cart	\$ 14,190
CC30M	30" Grill Vinyl Cover (Mobile Kitchen Cart)	\$ 629
LMKC54	54" Mobile Kitchen Cart	\$ 6,006

LYNX PROFESSIONAL GRILL CARTS



SHOWN: LYNX 54" MOBILE KITCHEN CART (LMKC54)

PRODUCT OVERVIEW

- Professional cart bases offer mobility and a freestanding option.
- Standard features include heavy-duty casters with locking brakes and convenient storage areas.

MODEL	DESCRIPTION	USD
L30CART	Cart for 30" Grill or Asado	\$ 3,858
LMKC54	Cart for 30" Grill or Asado	\$ 6,006
L36CART	Cart for 36" Grill	\$ 4,459
L42CART	Cart for 42" Grill	\$ 5,060
L54CART	Cart for 54" Grill	\$ 6,712

FREESTANDING SIDE BURNER / SLIDING TANK TRAY / COVERS



MODEL LCB2-3

CART MOUNTED DOUBLE SIDE BURNER

- Versatile intensity—two brass burners that you can turn from low simmer up to intense heat at 15,000 BTU
- Reliable speed—Hot Surface Ignition system lights burners quickly and safely
- Clean finish—burners and burner basin are sealed and easy to clean
- Striking illumination—luminous blue-lit control knobs
- Steadfast durability—heavy-duty welded construction eliminates gaps where grease can collect



MODEL LSTLP

SLIDING TANK TRAY

- Comfortable access—the sliding Liquid Propane tank tray provides safe and easy access
- Optional applications—available for freestanding 30", 42", 54" carts



FREESTANDING GRILL COVER

FREESTANDING GRILL COVER

- Perfect protection—a custom tailored fit
- Lasting resilience—tough textured vinyl
- Secure durability—pocket seams for lasting quality and a flexible cord for a close fit
- Quick placement—nylon finger loops help pull and secure the cover in place
- Tasteful elegance—deep embossed Lynx logo
- Delicate touch—felt lining protects stainless steel finishes
- Intelligent design—rear vent helps to expel moisture

MODEL	DESCRIPTION	USD
CC30F	30" Grill or Smoker Carbon Fiber Vinyl Cover (Freestanding)	\$ 465
CC30FCB	30" Carbon Fiber Vinyl Cover (Freestanding with Side Burner)	\$ 523
CC30M	30" Grill Vinyl Cover (Mobile Kitchen Cart)	\$ 629
CC36F	36" Carbon Fiber Vinyl Cover (Freestanding)	\$ 479
CC36FCB	36" Carbon Fiber Vinyl Cover (Freestanding with Side Burner)	\$ 540
CC42F	42" Carbon Fiber Vinyl Cover (Freestanding)	\$ 523
CC42FCB	42" Carbon Fiber Vinyl Cover (Freestanding with Side Burner)	\$ 570
CC54F	54" Carbon Fiber Vinyl Cover (Freestanding)	\$ 629
CC54FCB	54" Carbon Fiber Vinyl Cover (Freestanding with Side Burner)	\$ 765

NOTE: For planning and installation details, including dimensions, specification sheets, and CAD drawings please visit the Support/Product Documents section of the Lynx website: lynxgrills.com



LYNX SPECIALTY COOKING

A kitchen is more than a cook-top or a grill. It's the point around which entertaining revolves. All of our Lynx Specialty Cooking products are designed with every feature thought through, fully engineered, and crafted to give both you and your guests an elevated dining experience.

MIDDLEBY.COM.MX



NAPOLI OUTDOOR OVEN™

Gourmands around the world recognize the full flavors and evenly baked finish that can only be summoned from a stone oven.

The Napoli Outdoor Oven™ is a passport to another realm of outdoor cuisine. It can elicit the aromas of a rustic apple cake, rosemary braised lamb shanks, or a basil pesto flatbread. Finish your grilled salmon's garlic sesame sauce into a shimmering glaze.

The oven can be built into your kitchen or placed on a countertop or freestanding cart. The Napoli Outdoor Oven™ is capable of baking at 700°F, and hides an authentic refractory mortar dome beneath its elegant exterior. Impressive in beauty and function, the Napoli will broaden your bill of fare.

LYNX NAPOLI OUTDOOR OVEN™ — COUNTERTOP OR BUILT-IN



PRODUCT OVERVIEW

- Flexible capacity—400 square inches of cooking surface
- Powerful performance—preheats to 700°F (200°F hotter than most indoor ovens) for authentic stone oven baking
- Responsive adjustment—variable infrared heat
- Flexible configuration—reversible top chimney vents toward the front or back
- Stunning details—hand-polished mirrored edges
- Beautiful illumination—luminous blue-lit control knobs
- Powerful intensity—with a 40,000 BTU capacity
- Uncompromised construction—specially formulated concrete refractory interior dome and cooking surface
- Careful convenience—cooking surface pulls forward for easy access to food
- Secure enclosure—removable front door
- Perfect clarity—includes interior lighting
- Convenient extra—Includes 12¼" x 20" Pizza Peel
- 30" W x 29" H x 28.5" D

MODEL	DESCRIPTION	USD
LPZA	Napoli Outdoor Oven, Countertop or Built-In	\$ 8,935
CCLPZA	30" Napoli Outdoor Oven Carbon Fiber Vinyl Cover (Countertop)	\$ 314
CCLPZAB	30" Napoli Outdoor Oven Carbon Fiber Vinyl Cover (Built-In)	\$ 314
LPZANGK	Napoli Oven LP to NG Conversion Kit	\$ 59
LPZALPK	Napoli Oven NG to LP Conversion Kit	\$ 120

LYNX NAPOLI OUTDOOR OVEN™ — FREESTANDING



PRODUCT OVERVIEW

- Flexible capacity—400 square inches of cooking surface
- Powerful performance—preheats to 700°F (200°F hotter than most indoor ovens) for authentic stone oven baking
- Responsive adjustment—variable infrared heat
- Flexible configuration—reversible top chimney vents toward the front or back
- Stunning details—hand-polished mirrored edges
- Beautiful illumination—luminous blue-lit control knobs
- Powerful intensity—with a 40,000 BTU capacity
- Uncompromised construction—specially formulated concrete refractory interior dome and cooking surface
- Careful convenience—cooking surface pulls forward for easy access to food
- Secure enclosure—removable front door
- Perfect clarity—includes interior lighting
- Adaptable placement—freestanding application

MODEL	DESCRIPTION	USD
LPZAF	Napoli Outdoor Oven, Freestanding	\$ 14,943
LMKC54	54" Mobile Kitchen Cart	\$ 6,006
CCLPZAF	30" Napoli Outdoor Oven Carbon Fiber Vinyl Cover (Freestanding)	\$ 629
LPZANGK	Napoli Oven LP to NG Conversion Kit	\$ 59
LPZALPK	Napoli Oven NG to LP Conversion Kit	\$ 120

For great recipes, visit www.lynxgrills.com/recipes





ASADO COOKTOP

A grilled meal has no companion as decadent as one prepared on a flat-top grill—Yangzhou Fan fried rice, a fried pepper and onion topping, or just a mango salsa.

Awaken to the ease of orange crepes in the morning, greeting the day with a refreshing start in the cool outdoor air. The Lynx Asado Cooktop lets you expand your outdoor menu into Asian and fusion dishes that could only be made indoors before.

With a quick start and simple clean-up, it's tempting to call upon the Asado to add a highlight to every outdoor meal.

ASADO COOKTOP – BUILT-IN



PRODUCT OVERVIEW

- Precise power—two Trident™ Infrared Burners combining to provide up to 46,000 BTU
- Flexible capacity—495-square-inch dual-zone cooking surface
- Perfect surface—multi-layer grilling surface of aluminum sandwiched between two sheets of stainless steel
- Beautiful illumination—luminous blue-lit control knobs
- Reliable speed—Hot Surface Ignition system lights burners quickly and safely
- Quick clean-up—removable dual grease trays and removable grilling surface for easy cleaning
- Elegant protection—includes attractive stainless steel cover
- Steadfast durability—heavy-duty welded construction eliminates gaps where grease can collect

MODEL	DESCRIPTION	USD
L30AG	30" Asado Built-In Grill	\$ 8,184
LJJ30	Insulated Jacket for 30" Asado Built-In	\$ 1,441
CCASADO	30" Asado Carbon Fiber Vinyl Cover (built-in)	\$ 284

NOTE: Must specify gas type—NG for Natural Gas or LP for Propane

ASADO COOKTOP – FREESTANDING



30" ASADO ON 30" MOBILE KITCHEN CART
*SHOWN HERE: L30AG + L30CART. ASADO AND CART NEED TO BE ORDERED SEPARATELY
(ASSEMBLY REQUIRED)*

PRODUCT OVERVIEW

- Precise power—two Trident™ Infrared Burners combining to provide up to 46,000 BTU
- Flexible capacity—495-square-inch dual-zone cooking surface
- Perfect surface—multi-layer grilling surface of aluminum sandwiched between two sheets of stainless steel
- Beautiful illumination—luminous blue-lit control knobs
- Reliable speed—Hot Surface Ignition system lights burners quickly and safely
- Quick clean-up—removable dual grease trays and removable grilling surface for easy cleaning
- Elegant protection—includes attractive stainless steel cover
- Steadfast durability—heavy-duty welded construction eliminates gaps where grease can collect
- Convenient room—flat counter space to prep and serve, and a storage cabinet with two doors
- Ready to roll—built upon heavy-duty casters with brakes for easy mobility

MODEL	DESCRIPTION	USD
L30AG + L30CART	30" Asado Freestanding Grill	\$ 12,042
CCASADOF	30" Asado Carbon Fiber Vinyl Cover (freestanding)	\$ 434

NOTE: Must specify gas type—NG for Natural Gas or LP for Propane

ASADO COOKTOP – MOBILE KITCHEN CART



30" ASADO ON MOBILE KITCHEN CART
 SHOWN HERE: L30AG + LMKC54. ASADO AND CART NEED TO BE ORDERED SEPARATELY
 (ASSEMBLY REQUIRED)

PRODUCT OVERVIEW

- Precise power—two Trident™ Infrared Burners combining to provide up to 46,000 BTU
- Flexible capacity—495-square-inch dual-zone cooking surface
- Perfect surface—multi-layer grilling surface of aluminum sandwiched between two sheets of stainless steel
- Beautiful illumination—luminous blue-lit control knobs
- Reliable speed—Hot Surface Ignition system lights burners quickly and safely
- Quick clean-up—removable dual grease trays and removable grilling surface for easy cleaning
- Elegant protection—includes attractive stainless steel cover
- Steadfast durability—heavy-duty welded construction eliminates gaps where grease can collect
- Convenient room—flat counter space to prep and serve, and a storage cabinet with two doors and two drawers
- Ready to roll—built upon heavy-duty casters with brakes for easy mobility

MODEL	DESCRIPTION	USD
L30AG + LMKC54	30" Asado Grill on Mobile Kitchen Cart	\$ 14,190
LMKC54	54" Mobile Kitchen Cart	\$ 6,006
CCAGSERVE	Asado Grill or Serve Counter Carbon Vinyl Cover (Mobile Kitchen Cart)	\$ 554

NOTE: Must specify gas type—NG for Natural Gas or LP for Propane



PROFESSIONAL BURNERS

Sometimes, the difference is in the details.

And details are the specialty of Lynx Side Burners, with small sizes and flexible placements to perfectly capture your side dishes and toppings. Grill summer squash with oil and rosemary, melt a lemon butter sauce for your mahi-mahi, or warm a peanut curry sauce for your chicken. Even spectacular entrées can use an extra touch.

PROFESSIONAL BURNERS



MODEL LSB1-3

SINGLE SIDE BURNER

- Versatile intensity—one brass burner that you can turn from low simmer up to intense heat at 15,000 BTU
- Reliable speed—Hot Surface Ignition system lights burners quickly and safely
- Beautiful coverage—stainless steel cover to protect the burner when not in use
- Clean finish—burners and burner basin are sealed and easy to clean
- Striking illumination—luminous blue-lit control knobs
- Steadfast durability—heavy-duty welded construction eliminates gaps where grease can collect



MODEL LSB2-2

DOUBLE SIDE BURNERS

- Versatile intensity—two brass burners that you can turn from low simmer up to intense heat at 15,000 BTU
- Reliable speed—Hot Surface Ignition system lights burners quickly and safely
- Beautiful coverage—stainless steel cover to protect the burner when not in use
- Clean finish—burners and burner basin are sealed and easy to clean
- Striking illumination—luminous blue-lit control knobs
- Steadfast durability—heavy-duty welded construction eliminates gaps where grease can collect

MODEL	DESCRIPTION	USD
LSB1-3	Built-In Single Side Burner	\$ 1,817
LSB2-2	Built-In Double Side Burner	\$ 2,551
CCLSB1	Single Side Burner Carbon Fiber Vinyl Cover (Built-In)	\$ 178
CCLSB	Double Side Burner Carbon Fiber Vinyl Cover (Built-In)	\$ 209
LIJSB2	Double Side Burner Insulated Jacket	\$ 1,275

NOTE: Must specify gas type—NG for Natural Gas or LP for Propane; may require Lynx Accessory Switch Kit (LASK)

PROFESSIONAL BURNERS



MODEL LSB2PC-1

DOUBLE SIDE BURNERS W/ INTEGRAL PREP CENTER

- Versatile intensity—two brass burners that you can turn from low simmer up to intense heat at 15,000 BTU
- Ready room—the integral cutting board provides a convenient prep area
- Reliable speed—Hot Surface Ignition system lights burners quickly and safely
- Beautiful coverage—two removable stainless steel covers included, for the prep area and side burners
- Clean finish—burners and burner basin are sealed and easy to clean
- Spacious storage—the extended depth accommodates oversized grilling tools, towels, or wood chips
- Striking illumination—luminous blue-lit control knobs
- Steadfast durability—heavy-duty welded construction eliminates gaps where grease can collect



MODEL LPB

POWER BURNER

- Versatile intensity—letting you select from 3,000 up to 47,000 BTU
- Assured reliability—dual-ring red brass burner
- Copious space—the large grate surface accommodates an oversized stockpot
- Reliable speed—Hot Surface Ignition system lights burners quickly and safely
- Comprehensive coverage—fully extendable drip pan
- Innovative options—removable center grate lets you use a commercial-style wok
- Striking illumination—luminous blue-lit control knobs
- Beautiful coverage—removable stainless steel cover included

MODEL	DESCRIPTION	USD
LSB2PC-1	Double Side Burner with Integrated Prep Center	\$ 4,189
LPB	Power Burner	\$ 3,903
CCLSB2PC	Double Side Burner with Prep Center Carbon Fiber Vinyl Cover	\$ 253
CCLPB	Power Burner Carbon Fiber Vinyl Cover	\$ 253
LJJPB	Power Burner Insulated Jacket	\$ 1,411

NOTE: Must specify gas type—NG for Natural Gas or LP for Propane; may require Lynx Accessory Switch Kit (LASK)





WARMING DRAWER

The open air of outdoor cooking is a refreshing escape—and it's a fantastic place to entertain.

To keep all of the elements of your outdoor meal warm and ready, a Lynx warming drawer offer a generous capacity of safe and steady warmth.

You might even find that they're perfect for warming some plush pool towels while you swim.

WARMING DRAWER



MODEL L30WD-1

30" BUILT-IN WARMING DRAWER

- Adaptable range—temperature settings from 90° to 220°F, to keep breads warm or poultry piping hot
- Precision control—moist and crisp settings help maintain the perfect texture for your food
- Indicator light—reminds you when the drawer is on
- Fully featured—equipped with two removable steam pans, lids, and steam racks
- Hidden heating—a concealed heating element lets you use the warming drawer as a towel or robe warmer
- Lasting elegance—weather-resistant stainless steel construction



MODEL L42CC-1

42" WARMING DRAWER AND CONVENIENCE CENTER

- Compact convenience—a warming drawer, Liquid Propane tank storage cabinet, and utility drawer, all in one unit
- Spacious storage—the extended depth accommodates oversized grilling tools, towels, or wood chips
- Comprehensive options—warming drawer has two removable steam pans, lids, and steam racks
- Hidden heating—a concealed heating element lets you use the warming drawer as a towel or robe warmer
- Lasting elegance—weather-resistant stainless steel construction
- Comfortable access—the sliding Liquid Propane tank tray provides safe and easy access
- Adaptable range—temperature settings from 90° to 220°F, to keep breads warm or poultry piping hot
- Precision control—moist and crisp settings help maintain the perfect texture for your food
- Indicator light—reminds you when the drawer is on
- Stunning details—hand-polished mirrored highlights

MODEL	DESCRIPTION	USD
L30WD-1	30" Warming Drawer	\$ 3,858
L42CC-1	42" Convenience Center with Warming Drawe	\$ 6,487

NOTE: For planning and installation details, including dimensions, specification sheets, and CAD drawings please visit the Support/Product Documents section of the Lynx website: lynxgrills.com



LYNX OUTDOOR KITCHENS

With an outdoor kitchen, you'll always be ready for entertaining. Keep your food and drinks chilled, your dining essentials neatly stored and stylishly out of view. When all the elements to complete your outdoor dining picture are in order, you'll find that it's a space you want to spend your time—
time and again.

MIDDLEBY.COM.MX



REFRIGERATION

Relax. Even if it's not the time to grill, it's always time to pause and enjoy a chilled drink or crudité.

You will find that Lynx refrigerators play an indispensable role in your outdoor retreat. With intuitive features, perennial reliability, and excellence that you can feel in every movement, these pieces beckon you to come outside and relax.



MODEL L24TWS
SINGLE TOWER HEAD

MODEL L24TWD
DOUBLE TOWER HEAD

- Tailored integration—both tap towers work with the Lynx 24" Beverage Dispenser (LM24BFL and LM24BFR)

MODEL LN24BFL-1 / LN24BFR-1

Shown with: Optional L24TWD

24" BEVERAGE DISPENSER

- Lasting beauty—high-quality stainless steel
- Convenient display—digital readout
- Versatile uses—two half shelves for storing drinks
- Individualized fit—can be ordered right or left hinge
- Flexible expansion—compatible with Single Tower Head (L24TWS) and Double Tower Head (L24TWD) to convert into beer dispenser
- Striking effect—blue interior lighting
- Customized range—temperature range of 34°–60°F
- Simple security—the door locks for safety
- Helpful placements—secure CO2 tank storage area, drain bottle, and rear port for external CO2 tank option
- Keg compatibility—Designed for half kegs, pony kegs, and sixth barrels/cornelius kegs
- Tested safety—UL listed for outdoor use
- Optional taps—sold separately



MODEL LN24DWR

24" REFRIGERATOR DRAWER

- Substantial room—5 cubic feet of space
- Responsive performance—dynamic cooling technology allows real-time temperature control
- Striking effect—blue interior lighting
- Innovative alerts—alarm indicates when the door is ajar, or if the temperature changes by more than 10°F in an hour, to protect food and save energy
- Complete access—full-extension glide-out drawer slides for access to the back of the drawer
- Simple security—the drawer locks for safety
- Customized range—temperature range of 34°–42°F
- Tested safety—UL listed for outdoor use
- Proven efficiency—Energy Star rated



MODEL	DESCRIPTION	USD
L24TWS	Single Tap Tower Kit	\$ 1,291
L24TWD	Double Tap Tower Kit	\$ 1,875
LN24BFL-1 / LN24BFR-1	24" Beverage Dispenser	\$ 6,818
CCTWR	24" Beverage Dispenser / Single Tower Tap Head Carbon Fiber Vinyl Cover	\$ 148
CCTWD	24" Beverage Dispenser/ Double Tower Tap Head Carbon Fiber Vinyl Cover	\$ 164
LN24DWR	24" Two Drawer Refrigerator	\$ 8,651

REFRIGERATION



MODEL LN24REFGL / LN24REFGR 24" OUTDOOR REFRIGERATOR WITH GLASS DOOR

- Easy visibility—Glass Door Front
- Plentiful room—5.3 cubic feet of space
- Responsive performance—dynamic cooling technology allows real-time temperature control
- Striking effect—blue interior lighting
- Ample access—a 24-inch wide refrigerator to keep everything chilled
- Flexible configuration—two fully adjustable stainless steel shelves
- Individualized fit - can be ordered right or left hinge
- Simple security—the door locks for safety
- Customized range—temperature range of 34°–42°F
- Tested safety—UL listed for outdoor use
- Proven efficiency—Energy Star rated



MODEL LN24REFL / LN24REFR 24" REFRIGERATOR

- Plentiful room—5.3 cubic feet of space
- Responsive performance—dynamic cooling technology allows real-time temperature control
- Striking effect—blue interior lighting
- Ample access—a 24-inch wide refrigerator to keep everything chilled
- Flexible configuration—two fully adjustable stainless steel shelves
- Individualized fit - can be ordered right or left hinge
- Simple security—the door locks for safety
- Customized range—temperature range of 34°–42°F
- Tested safety—UL listed for outdoor use
- Proven efficiency—Energy Star rated



MODEL LM24REFCL / LM24REFCR 24" REFRIGERATOR & FREEZER COMBINATION

- Plentiful room—the refrigerator has 3.9 cubic feet of space
- Space to chill—the freezer has a self-closing door and 1 cubic foot of capacity (enough for 12 pints of ice cream)
- Individualized fit - can be ordered right or left hinge
- Striking effect—blue interior lighting
- Innovative alerts—audible and visual alarms indicate when the door is ajar, to protect food and save energy
- Variable storage—adjustable shelves easily meet your needs
- Optional expansion—an optional ice maker kit can produce and store up to 13 pounds of crescent ice (LMICEKIT)
- Lasting beauty—high-quality stainless steel
- Proven reliability—tested to perform in temperatures up to 115°F
- Worry-free convenience—automatic defrost for frost-free freezer operation
- Certified durability—CSA certified for outdoor use to withstand elements like rain, high humidity and heat
- Proven efficiency—Energy Star rated

COMING SOON: LN24REFCL/CR will replace current models in 2023

MODEL	DESCRIPTION	USD
LN24REFGL / LN24REFGR	24" Outdoor Refrigerator with Glass Door	\$ 6,248
LN24REFL/R	24" Outdoor Refrigerator	\$ 5,691
LM24REFCL/R	24" Outdoor Refrigerator & Freezer Combination	\$ 7,029

REFRIGERATION



MODEL LN15REFL / LN15REFR

15" REFRIGERATOR

- Plentiful room—2.73 cubic feet of space
- Responsive performance—dynamic cooling technology allows real-time temperature control
- Striking effect—blue interior lighting
- Flexible configuration—two fully adjustable stainless steel shelves
- Simple security—the door locks for safety
- Customized range—temperature range of 34°–42°F
- Individualized fit—can be ordered right or left hinge
- Tested safety—UL listed for outdoor use
- Proven efficiency—Energy Star rated



MODEL LN15WINEL / LM15WINER

15" WINE CELLAR

- Plentiful room—2.7 cubic feet of space
- Capacity in case—stores up to 24 bottles
- Striking effect—Black interior with blue interior lighting
- Patient protection—cushions wine against agitation while it matures
- Steady support—four sturdy wine racks are shaped to cradle each wine bottle
- Complete access—full-extension gliding shelves slide out for access
- Quiet cooling—the exclusive design buffers and minimizes sound
- Individualized fit—can be ordered right or left hinge
- **COMING SOON:** LN15WINER will replace current model in 2023



MODEL LN15ICE

15" OUTDOOR ICE MACHINE

- Generous capacity—produces up to 39 pounds of ice
- Innovative alerts—audible alerts and programmed cleaning reminders
- Crystal clarity—produces pure, clear ice with unrivaled clarity
- Striking effect—blue interior lighting
- Gentle closing—close door assist system
- Lasting beauty—high-quality stainless steel
- Individualized fit—aligned for a right hinge
- Certified durability—CSA certified for outdoor use to withstand elements like rain, high humidity and heat
- Optional drain pump (LM15ICE-DP)
- Field-reversible door

MODEL	DESCRIPTION	USD
LN15ICE	15" Outdoor Ice Machine	\$ 7,057
LM15ICE-DP	Optional Drain Pump for 15" Outdoor Ice Machine	\$ 1,547
LN15REFL/R	15" Outdoor Refrigerator	\$ 5,330
LN15WINEL/LM15WINER	15" 20 Bottle Wine Cellar	\$ 7,299



VENTANA STORAGE COLLECTION

The Lynx Ventana Collection of elegant outdoor storage solutions is named after the Ventana Wilderness, 240,000 acres along the Big Sur coast in central California that is renowned as a destination for restoration of the spirit and soul. This coast has been described as “the greatest meeting of mountains and sea”.

Combining beauty with functionality, smooth front facings, recessed handles, and handcrafted framing merge to form a sleek and contemporary balance to your Lynx outdoor kitchen. Dust and water resistant, each door and drawer softly closes itself as if to punctuate the elegance of an artistic statement. The Ventana Collection from Lynx proves that small things can make a big difference.

VENTANA STORAGE COLLECTION



MODELS LSA30-4 / LSA36-4 / LSA42-4

OUTDOOR KITCHEN STORAGE SYSTEM

- Generous depth—each drawer is 25.5 inches deep
- Perfect completion—soft-close drawer slides
- Tidy enclosure—rubber trim around the frame helps block dust and water
- Quick cleaning—easy-to-clean stainless steel surface
- Elegant simplicity—designed with understated style
- Essential storage—a 30-inch-wide door and double drawer combination
- Striking effect—interior lighting for drawers and cabinet
- Perfect ending—soft-close door hinge
- Subtle convenience—flush-mounted reversible handle is there when you need it
- Perennial refinement—clean design eliminates places that dirt can collect
- Expandable options—door accessory kits available

MODELS LDR18L-4 / LDR18R-4 / LDR24L-4 / LDR24R-4 LDR30T-4 / LDR36T-4 / LDR42T-4

SINGLE ACCESS DOORS / DOUBLE ACCESS DOORS

- 18", 24", 30", 36" & 42" sizes available
- Tidy enclosure—rubber trim around the frame helps block dust and water
- Subtle convenience—flush-mounted reversible handle is there when you need it
- Perennial refinement—clean design eliminates places that dirt can collect
- Expandable options—door accessory kits available
- Quick cleaning—easy-to-clean stainless steel surface
- Elegant simplicity—designed with understated style
- Perfect ending—soft-close hinge

MODELS LDRKS / LDRKL

DOOR ACCESSORY KIT

- Handy convenience—includes two bottle holders and a towel bar
- Versatile application—fits doors that are 18 or 30 inches (LDRKS) or 24, 36, or 42 inches (LDRKL)

VENTANA STORAGE COLLECTION



MODEL LPA36-4

36" SEALED PANTRY

- Complete access—full-extension glide-out drawer slides for access to the back of the drawer
- Striking effect—blue interior lighting for drawers
- Quick cleaning—easy-to-clean stainless steel surface
- Elegant simplicity—designed with understated style
- Clean storage—the magnetic gasket ensures a tight seal against outdoor elements
- Flexible use—adjustable wire shelf
- Spacious room—storage is 31 by 18 by 23 inches
- Perennial refinement—clean design eliminates places that dirt can collect
* may require Lynx Accessory Switch Kit for power supply (LASK)



MODEL LMD-4

MODULAR STORAGE DRAWER

- Lasting beauty—high-quality stainless steel
- Complete access—full-extension glide-out drawer slides for access to the back of the drawer
- Variable configuration—drawers can be installed individually, or as two or three drawers stacked
- Consistent lines—the 3-drawer configuration matches the height of Lynx LDR Access Doors
- Optional expansion—a modular drawer kit (Model LMD-KIT) lets you stack drawers two or three high



MODEL LDW16-4

UTILITY DRAWERS - DOUBLE DRAWER

- Lasting beauty—high-quality stainless steel
- Complete access—full-extension glide-out drawer slides for access to the back of the drawer
- Variable configuration—drawers can be installed individually, or as two or three drawers stacked
- Tidy enclosure—rubber trim around the frame helps block dust and water
- Perfect completion—soft close drawer slides

VENTANA STORAGE COLLECTION



MODEL LDW19-4

UTILITY DRAWERS - EXTRA LARGE DOUBLE DRAWER

- Extensive storage—the extended depth of 22 inches accommodates oversized grilling tools, towels, or wood chips
- Stable strength—rigid welded construction ensures strength and longevity
- Tidy enclosure—rubber trim around the frame helps block dust and water
- Quick cleaning—easy-to-clean stainless steel surface
- Elegant simplicity—designed with understated style
- Ample width—each drawer exterior is 19 inches wide
- Smooth reliability—fully extendable drawers on commercial stainless steel rollers
- Perfect completion—soft-close drawer slides
- Subtle convenience—flush-mounted reversible handle is there when you need it
- Perennial refinement—clean design eliminates places that dirt can collect



MODEL L20TR-4

OUTDOOR TRASH & RECYCLE CENTER

- Quick clean-up—includes two removable receptacles for recycling and trash
- Subtle convenience—flush-mounted reversible handle is there when you need it
- Elegant simplicity—designed with understated style
- Tidy enclosure—rubber trim around the frame helps block dust and water
- Perennial refinement—clean design eliminates places that dirt can collect



MODEL LTA30-4

30" TRASH CENTER & DOUBLE DRAWERS

- Quick clean-up—includes a removable receptacle for recycling or trash
- Convenient storage—with two stacked drawers
- Subtle convenience—flush-mounted reversible handle is there when you need it
- Perennial refinement—clean design eliminates places that dirt can collect
- Efficient space—combination trash center and storage system
- Easy fit—accommodates an LP gas tank
- Tidy enclosure—rubber trim around the frame helps block dust and water
- Quick cleaning—easy-to-clean stainless steel surface
- Elegant simplicity—designed with understated style, illuminated drawers & door space

VENTANA STORAGE COLLECTION



MODEL LTWL

TOWEL DISPENSER

- Solid feel—heavy-duty welded construction
- Tidy enclosure—rubber trim around the frame helps block dust and water
- Subtle convenience—flush-mounted reversible handle is there when you need it
- Artful placement—provides an appealing concealed storage for paper towels
- Customized access—the door swings down
- Perfect ending—soft-close hingeFlush mounted reversible handle

MODEL LTB

14" TOWEL BAR

- Versatile placement—towel bar can be mounted on the outdoor kitchen
- Flawless finish—solid stainless steel hardware
- Solid feel—heavy-duty welded construction

MODEL L18TS

COUNTERTOP TRASH CHUTE

- Quick access—offers convenient countertop trash disposal
- Intuitive convenience—commercial-style slide-away chopping board
- Versatile integration—works with any Lynx trash center
- Beautiful coverage—stainless steel cover with a polished highlight included

MODEL	DESCRIPTION	USD
LPA36-4	Sealed Pantry	\$ 4,579
LMD-4	Modular Drawer (single drawer)	\$ 1,141
LMD-KIT	Modular Drawer Kit (allows you to stack model LMD 2 or 3 high)	\$ 178
LDW16-4	Double Drawers	\$ 1,875
LDW19-4	Extra Large Double Drawers	\$ 2,507
LSA30-4	30" Access Door Drawer Combination	\$ 2,687
LSA36-4	36" Access Door Drawer Combination	\$ 2,927
LSA42-4	42" Access Door Drawer Combination	\$ 3,124
LDR18L-4	18" Single Access Door (Hinge Left)	\$ 974
LDR18R-4	18" Single Access Door (Hinge Right)	\$ 974
LDR24L-4	24" Single Access Door (Hinge Left)	\$ 1,155
LDR24R-4	24" Single Access Door (Hinge Right)	\$ 1,155
LDR30T-4	30" Double Access Doors	\$ 1,246
LDR36T-4	36" Double Access Doors	\$ 1,425
LDR42T-4	42" Double Access Doors	\$ 1,530
LDRKS	Door Accessory Pack Includes: 2 bottle holders & 1 Towel Bar & Mounting Kit for 18" & 30" doors	\$ 373
LDRKL	Door Accessory Pack Includes: 2 bottle holders & 1 Towel Bar & Mounting Kit for 24", 36" & 42" doors	\$ 523
L20TR-4	Lynx 20" Trash & Recycle Bins - Slide-out, Framed	\$ 1,861
LTA30-4	30" Trash Center & Double Drawer Combo	\$ 2,626
LTWL	Paper Towel Dispenser	\$ 765
LTB	Towel Bar	\$ 298
L18TS	Countertop Trash Chute with Cutting Board	\$ 779
CCTS	Trash Chute Carbon Fiber Vinyl Cover	\$ 148

NOTE: For planning and installation details, including dimensions, specification sheets, and CAD drawings please visit the Support/Product Documents section of the Lynx website: lynxgrills.com





CLASSIC STORAGE COLLECTION

To create the ultimate cuisine, and a have where you feel at home, you should have all that you need close at hand.

With Lynx Classic Storage, you can complete your space.

With beautiful finishes, generous storage, easy cleanup, and thoughtful details, these pieces pair perfectly and extend the elegant look of your Lynx cooking devices.

Create a place that goes beyond cooking. Create a place that's always waiting for you—a place where you want to stay.

CLASSIC STORAGE COLLECTION



MODEL LSA30 / LSA36 / LSA42

OUTDOOR KITCHEN STORAGE SYSTEM

- Essential storage—30" 36" or 42" wide door and double drawer combination
- Reassuring security—the door has a key lock
- Complete access—full-extension glide-out drawer slides for access to the back of the drawer
- Elegant touch—polished door handles
- Stable strength—rigid welded construction ensures strength and longevity
- Striking effect—interior lighting for drawers and cabinet
- Flawless finishing—fully lined drawer
- Quick clean-up—the in-door condiment shelf is removable for easy cleaning
- Confident closure—heavy-duty latches for easy closing



MODEL LDW16 / LDW19

DOUBLE DRAWERS

- Ample width—each drawer exterior is 16 inches wide
- Smooth reliability—fully extendable drawers on commercial stainless steel rollers
- Elegant touch—polished door handles
- Extensive storage—the extended depth of 21 inches accommodates oversized grilling tools, towels, or wood chips
- Stable strength—rigid welded construction ensures strength and longevity



MODEL LDR18L / LDR18R / LDR24L / LDR24R / LDR30T / LDR36T / LDR42T

SINGLE ACCESS DOORS / DOUBLE ACCESS DOORS

- Perfect fit—18", 24", 30", 36" and 42" sizes available
- Elegant touch—polished door handles
- Stable strength—rigid welded construction ensures strength and longevity
- Quick clean-up—the in-door condiment shelf is removable for easy cleaning
- Confident closure—heavy-duty latches for easy closing





MODEL L20TR

OUTDOOR TRASH CENTER

- Attractive convenience—concealed option with two receptacles for recycling and trash
- Stunning details—hand-polished mirrored highlights
- Elegant touch—Lynx Professional style door handle
- Stable strength—rigid welded construction ensures strength and longevity



MODEL LTA30

30" TRASH CENTER & DOUBLE DRAWERS

- Efficient space—combination trash center and storage system
- Quick clean-up—includes a removable receptacle for recycling or trash
- Convenient storage—with two stacked drawers
- Proven durability—robust commercial design
- Easy fit—accommodates a small trash bin or an LP gas tank
- Elegant touch—polished door handles

CLASSIC STORAGE COLLECTION



MODEL LMD

MODULAR STORAGE DRAWER

- Lasting beauty—high-quality stainless steel
- Variable configuration—drawers can be installed individually, or as two or three drawers stacked
- Optional expansion—a modular drawer kit (Model LMD-KIT) lets you stack drawers two or three high
- Complete access—full-extension glide-out drawer slides for access to the back of the drawer
- Consistent lines—the 3-drawer configuration matches the height of Lynx LDR Access Doors



MODEL LPA36

36" CLASSIC SEALED PANTRY

- Clean storage—magnetic gasket ensures a tight seal against outdoor elements
- Flexible storage—adjustable wire shelf
- Spacious storage—storage is 31 by 18 by 20 inches
- Complete access—full-extension glide-out drawer slides for access to the back of the drawer
- Striking effect—interior lighting for drawers and door lock

CLASSIC STORAGE COLLECTION



MODEL L18TS

COUNTERTOP TRASH CHUTE

- Quick access—offers convenient countertop trash disposal
- Intuitive convenience—commercial-style slide-away chopping board
- Versatile integration—works with any Lynx trash center
- Beautiful coverage—stainless steel cover with a polished highlight included

MODEL	DESCRIPTION	USD
LDR18L	18" Access Door (Hinge Left)	\$ 765
LDR18R	18" Access Door (Hinge Right)	\$ 765
LDR24L	24" Access Door (Hinge Left)	\$ 871
LDR24R	24" Access Door (Hinge Right)	\$ 871
LDR30T	30" Access Doors	\$ 1,066
LDR36T	36" Access Doors	\$ 1,260
LDR42T	42" Access Doors	\$ 1,366
LSA30	30" Door Drawer Combination	\$ 2,568
LSA36	36" Door Drawer Combination	\$ 2,837
LSA42	42" Door Drawer Combination	\$ 3,049
LPA36	36" Sealed Pantry	\$ 4,504
LDW16	Double Drawer 16" Wide (soft close)	\$ 1,817
LDW19	Double Drawer 19" Wide (soft close)	\$ 2,476
LMD	Modular Drawer (single drawer)	\$ 1,124
LMD-KIT	Modular Drawer Kit (allows you to stack model LMD 2 or 3 high)	\$ 178
LTA30	30" Trash and Double Drawers	\$ 2,568
L20TR	Trash and Recycle Center	\$ 1,817
L18TS	Trash Chute	\$ 779

NOTE: For planning and installation details, including dimensions, specification sheets, and CAD drawings please visit the Support/Product Documents section of the Lynx website: lynxgrills.com





SINKS AND COCKTAIL STATIONS

Outdoor kitchens create experiences, and inspire conversations, that don't happen anywhere else. To keep your attention on the things that matter, you need a simple place for rinsing, filling, or washing without stepping away.

SINKS AND COCKTAIL STATIONS



MODEL LSK30

30" SINK

- Generous space—basin is 26.75 by 16.5 by 10 inches, has a 3.5-inch drain with stopper and basket, and accommodates disposal units
- Thorough chilling—fully insulated with capacity for 30 pounds of ice
- Striking effect—blue lighting and switch
- Beautiful coverage—stainless steel cover included



MODEL LSK24

24" SINK

- Generous space—basin is 20.75 by 16.5 by 10 inches, has a 3.5-inch drain with stopper and basket, and accommodates disposal units
- Beautiful coverage—stainless steel cover included
- Thorough chilling—fully insulated with capacity for 24 pounds of ice
- Striking effect—blue lighting and switch



MODEL LSK18

18" SINK

- Convenient depth—basin is 18.75 by 16.5 by 10 inches, has a 3.5-inch drain with stopper and basket, and accommodates disposal units
- Beautiful coverage—stainless steel cover included
- Thorough chilling—fully insulated with capacity for 18 pounds of ice
- Striking effect—blue lighting and switch



MODEL LPFK

GOOSENECK PULL-DOWN FAUCET

- Flexible use—features a pull-down faucet head
- Lasting assurance—outdoor rated with a 10-year warranty
- Long-lasting design—carefully engineered to operate without washers
- Easy functionality—easily operates with a single-lever handle
- Flawless finish—solid stainless steel faucet
- Versatile configuration—install for hot/cold or cold-only water
- Elegant simplicity—designed with understated style
- Tested efficiency—compliant with California Energy Commission (CEC) standards



MODEL LCS30

30" BUILT-IN COCKTAIL PRO

- Quick convenience—built-in bottle opener with cap catcher
- Intuitive design—bottle boots chill juices, wines, and mixes while the speedrail front offers easy access to bottle storage
- Eye-catching illumination—blue lighting on the front panel
- Ready to chill—the insulated ice bin with sliding stainless steel cover keeps ice at the ready all day
- Intuitive convenience—integrated towel holder
- Includes the LPFK Gooseneck Pull-Down Faucet



MODEL LCS30F

30" FREESTANDING COCKTAIL PRO

Same features as LCS30 (left) plus:

- Quick expansion—two fold-down shelves
- Easy clean-up—doors include bottle shelves that are removable for easy cleaning
- Ready to roll—four commercial casters make these units easy to move
- Optional expansion—shown with optional pass shelf and halogen light (LCSPS)
- Beautiful coverage—stainless steel cover included

MODEL	DESCRIPTION	USD
LSK18	18" Insulated Sink	\$ 2,192
LSK24	24" Insulated Sink	\$ 2,626
LSK30	30" Insulated Sink	\$ 3,063
LPFK	Pull Down Gooseneck Faucet	\$ 871
LCS30	Built-In Cocktail Pro Station	\$ 4,370
LCS30F	Freestanding Cocktail Pro Station	\$ 5,961
LCSPS	Pass Shelf accessory with halogen light	\$ 1,066
CCLSK18	18" Sink Carbon Fiber Vinyl Cover (for sink with faucet LPFK)	\$ 284
CCLSK24	24" Sink Carbon Fiber Vinyl Cover (for sink with faucet LPFK)	\$ 298
CCLSK30	30" Sink or 30" Cocktail Carbon Fiber Vinyl Cover (for sink/cocktail pro with faucet LPFK)	\$ 314

NOTE: For planning and installation details, including dimensions, specification sheets, and CAD drawings, please visit the Support/Product Documents section of the Lynx website: lynxgrills.com

OUTDOOR HEATING



Shown: LEH39



MODEL LEH39

39" DUAL ELEMENT ELECTRIC HEATER

- Includes dual stacked control
- 4000 Watt, 240 Volt capacity
- 8-12' mounting height
- UL Listed for outdoor use
- 8 x 10' heat coverage
- Approximately 5000 hours of use per element

Shown: Dual Stacked Control on Mounting Plate
(Mounting Plate not included)
Included with both LEH39 and LEH61

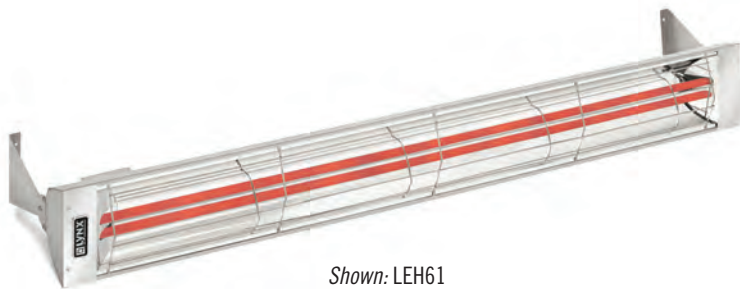

Shown: LEH61

MODEL LEH61

61" DUAL ELEMENT ELECTRIC HEATER

- Includes dual stacked control
- 6000 Watt, 240 Volt capacity
- 10-14' mounting height
- UL Listed for outdoor use
- 11 x 11' heat coverage
- Approximately 5000 hours of use per element

OUTDOOR HEATING

The Lynx Life awaits you all year round. Outdoor heaters help you extend those late-night conversations and early-morning reflections. Savor the crisp Fall and Winter seasons as you host celebrations or take time to contemplate.

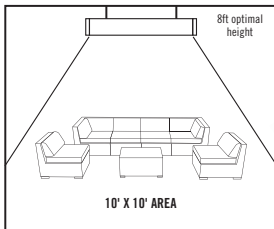

MODEL LHEM48

48" EAVE-MOUNTED OUTDOOR HEATER

- Lasting elegance—Lynx legendary all-stainless-steel welded construction
- Functional beauty—decorative safety grill provides wind resistance
- Expansive warmth—heats up to a 10-by-10-foot area, depending on location and height
- Independent freedom—starter is battery operated, with no outlet required
- Impressive control—includes an additional touch screen remote control
- Elegant simplicity—designed with understated style
- Versatile adaptation—operates with Liquid Propane or Natural Gas
- Consistent assurance—direct spark ignition with automatic relighting
- Adaptive configuration—includes a wireless wall-mounted switch with on/off/high/low settings
- Variable Output from 35,000 BTUs to 24,000 BTUs
- Temperature control from 45°–90° F

MODEL	DESCRIPTION	USD
LEH39	39" Dual Element electric heater	\$ 1,141
LEH61	61" Dual Element electric heater	\$ 1,335
FMKIT39	Flush Mount Frame Kit for LEH39	\$ 871
FMKIT61	Flush Mount Frame Kit for LEH61	\$ 929
LERE2024	Replacement Element for LEH39	\$ 239
LERE3024	Replacement Element for LEH61	\$ 284
LHEM48	Eave-Mounted Heater	\$ 4,384



ACCESSORIES

Lynx Accessories help compliment and complete your Lynx outdoor kitchen. Choose the final touches that complete your perfect picture. The details matter.

MIDDLEBY.COM.MX

ACCESSORIES



MODEL LSTK

LYNX STEAK KNIFE SET

- Complete preparation—set includes six 5-inch steakhouse-style knives with a beautiful wooden case
- Magnificent quality—crafted from German stainless steel delivers perfect performance
- Elegant finish—polished black and stainless steel handles



MODEL RB8

ROTISSERIE BASKET

- Brilliant versatility—great for vegetables, chicken wings, and more
- Easy addition—compatible with any Lynx or Sedona rotisserie grill
- Flexible placement—works with both the rear rotisserie burner or standard grilling burners
- Quick clean-up—easy to clean and dishwasher safe



MODEL GP

GRIDDLE PLATE

- Amazing options—cook anything on your grill
- Generous space—11" x 15" cooking surface
- Thoughtful design—angled 5° slope front to rear to prevent spillage, and 2" high sides
- Stable placement—four feet firmly grip grates
- Quick clean-up—easy-to-clean stainless steel surface

ACCESSORIES



LYNX SONOMA BLEND SMOKING CHIPS

- Delicious options—available in four different flavors: Pecan, Apple, Mesquite and Hickory
- Easy to use—no soaking required

MODEL	DESCRIPTION	USD
LSTK	Lynx Steak Knife Set	\$ 284
RB8	Rotisserie Basket	\$ 554
GP	Griddle Plate	\$ 629
PROLPK1	Grill / Side Burner / Power Burner - NG to LP Conversion Kit	\$ 209
PRONGK1	Grill / Side Burner / Power Burner - LP to NG Conversion Kit	\$ 134
LPEK	12' extension cord between a Lynx Grill and a Lynx Accessory	\$ 73
LASK	Lynx Accessory Switch Kit - Switch & transformer to operate an accessory independently	\$ 239
ADAKIT	Kit includes 4 Knobs & 1 Hood Handle	\$ 509
LSCA	Woodchip Blend, Apple	\$ 28
LSCH	Woodchip Blend, Hickory	\$ 28
LSCM	Woodchip Blend, Mesquite	\$ 28
LSCP	Woodchip Blend, Pecan	\$ 28
LSCF	Woodchip Blend - Four Pack: Apple, Hickory, Mesquite & Pecan	\$ 120
WGO300	Windscreen – 30" Grills	\$ 270
WGO360	Windscreen – 36" Grills	\$ 314
WGO420	Windscreen – 42" Grills	\$ 359
WGO540	Windscreen – 54" Grills	\$ 390
LBR411	Regulator for LP bulk tank installation	\$ 73

NOTE: For planning and installation details, including dimensions, specification sheets, and CAD drawings please visit theSupport/Product Documents section of the Lynx website: lynxgrills.com

SPECIFICATIONS

The guides, measurements, and dimensions detailed below are designated to assist you with planning your outdoor kitchen. **NOTE:** Due to continuing product innovation, specifications are subject to change without notice. All measurements are in inches. **IMPORTANT:** Please reference the Care & Use / Installation manual for details on gas plumbing requirements, electrical specifications, and the proper installation of your Lynx outdoor kitchen equipment. This manual can be downloaded from the Lynx website at www.lynxgrills.com

NOTE: For planning and installation details, including dimensions, specification sheets, and CAD drawings please visit the Trade Resources section of the Lynx website: lynxgrills.com

Lynx offers bulk LP installation kits (Model LBR411) for all LP grills (converts grill from LP to bulk LP). Installation must be done by a licensed installer, plumber or authorized gas professional. Bulk kits are not available for natural gas plumbed grills, and they are only available for U.S. customers.

54" GRILL DIMENSIONS & ISLAND PREPARATION

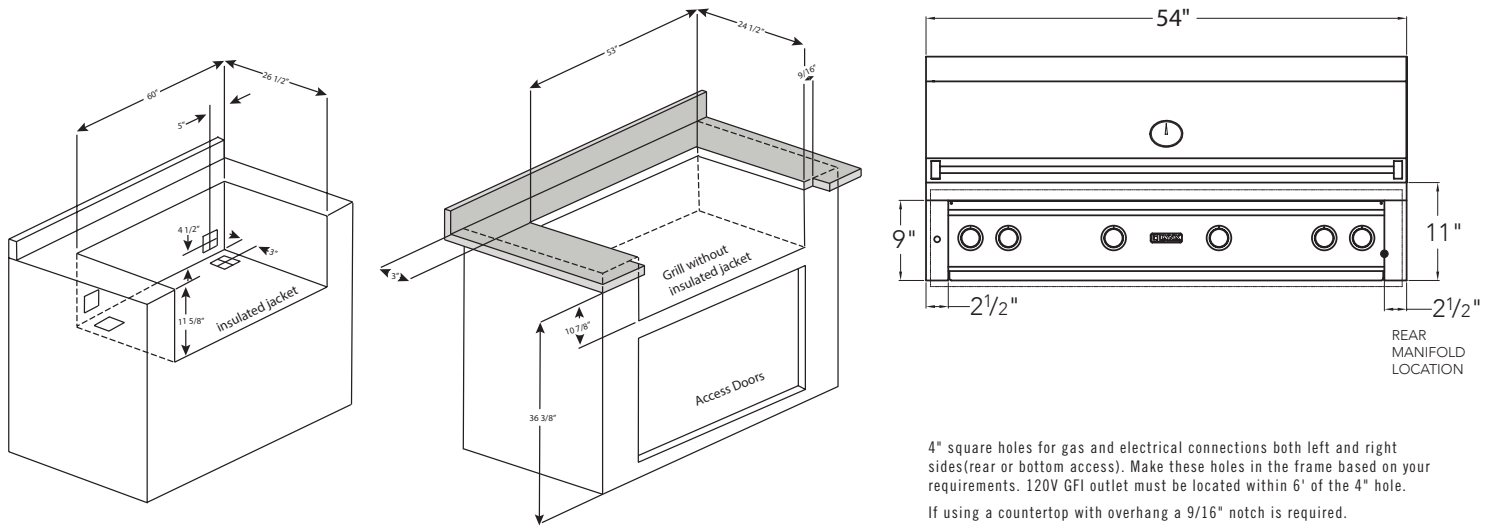

4" square holes for gas and electrical connections both left and right sides (rear or bottom access). Make these holes in the frame based on your requirements. 120V GFI outlet must be located within 6' of the 4" hole.
If using a countertop with overhang a 9/16" notch is required.
Use insulated jacket when installing grills in combustible material island.

42" GRILL DIMENSIONS & ISLAND PREPARATION

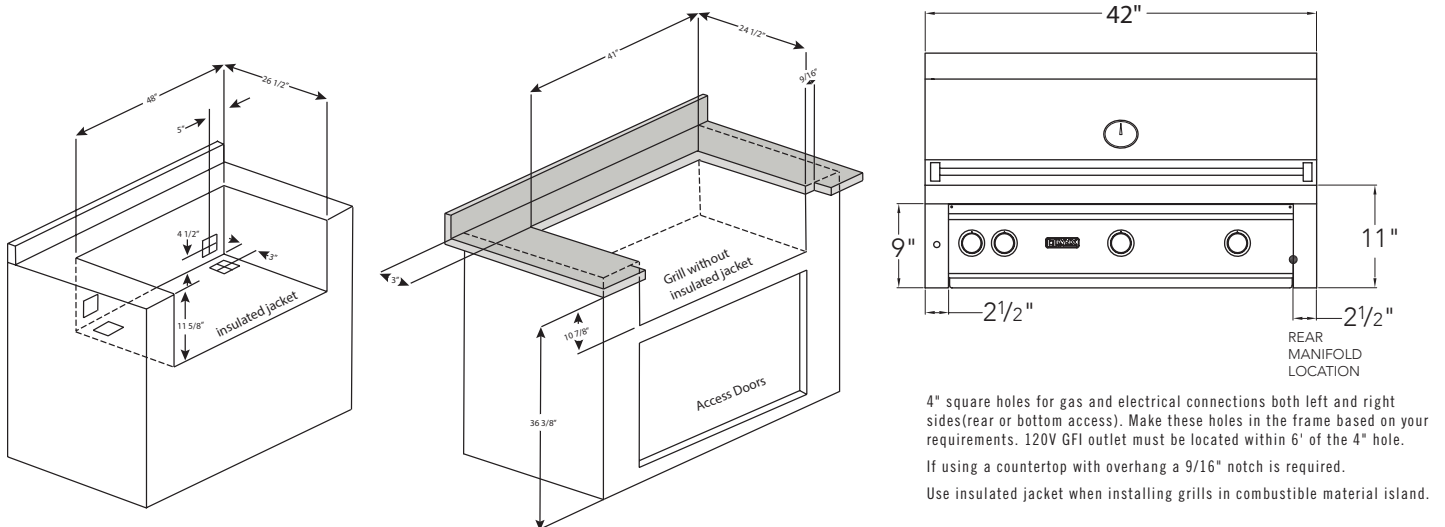

4" square holes for gas and electrical connections both left and right sides (rear or bottom access). Make these holes in the frame based on your requirements. 120V GFI outlet must be located within 6' of the 4" hole.
If using a countertop with overhang a 9/16" notch is required.
Use insulated jacket when installing grills in combustible material island.

SPECIFICATIONS

36" GRILL DIMENSIONS & ISLAND PREPARATION

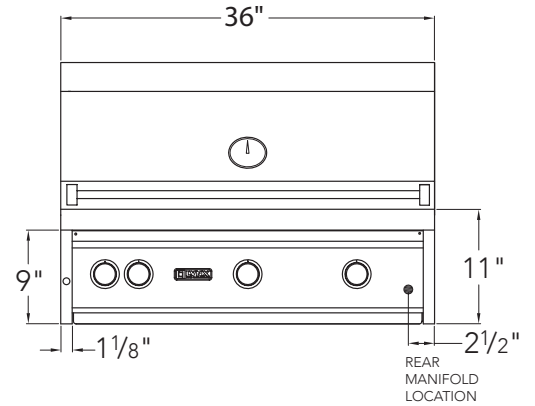
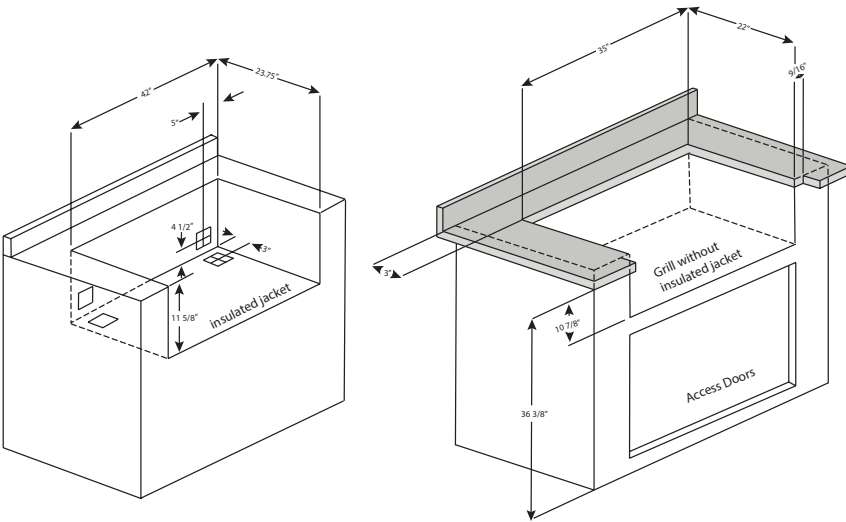

4" square holes for gas and electrical connections both left and right sides(rear or bottom access). Make these holes in the frame based on your requirements. 120V GFI outlet must be located within 6' of the 4" hole.

If using a countertop with overhang a 9/16" notch is required.

Use insulated jacket when installing grills in combustible material island.

30" GRILL DIMENSIONS & ISLAND PREPARATION

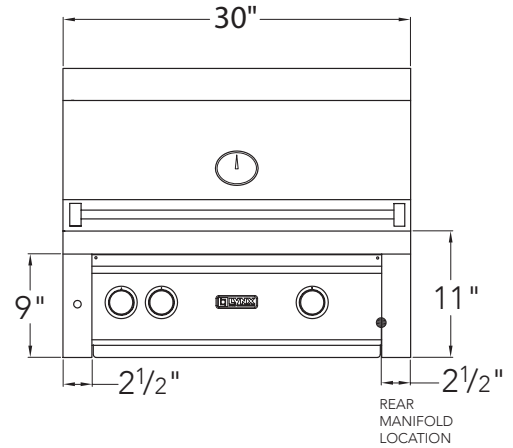
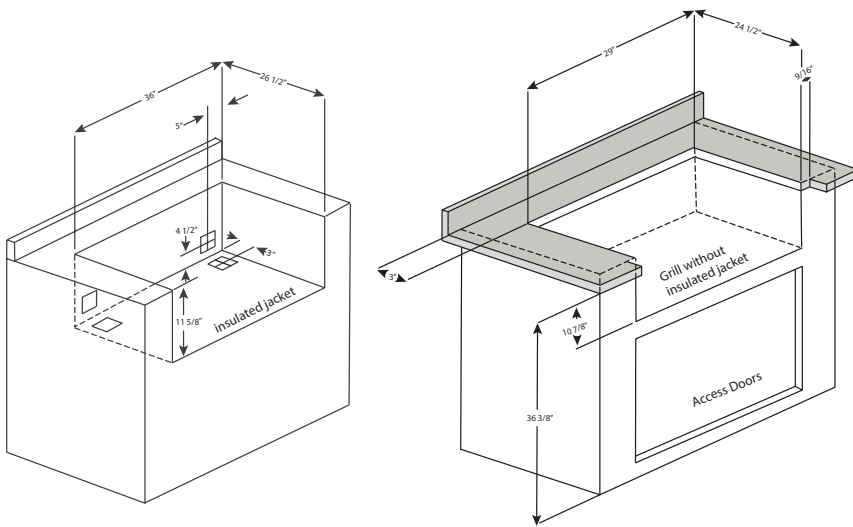

4" square holes for gas and electrical connections both left and right sides(rear or bottom access). Make these holes in the frame based on your requirements. 120V GFI outlet must be located within 6' of the 4" hole.

If using a countertop with overhang a 9/16" notch is required.

Use insulated jacket when installing grills in combustible material island.

SPECIFICATIONS

BUILT-IN GRILL SPECIFICATIONS & INSTALLATION

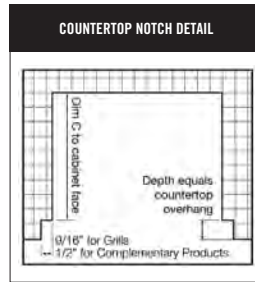
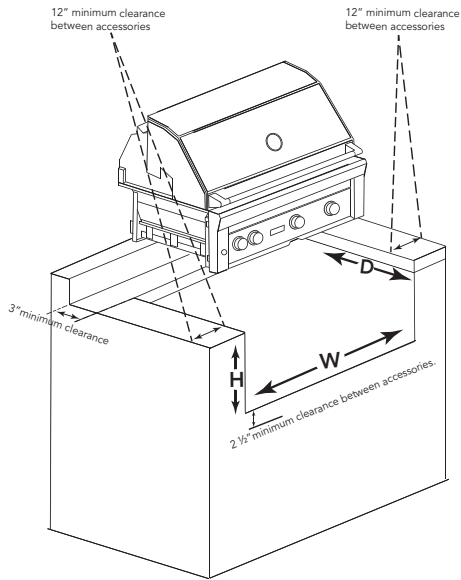

GRILLS

MODEL	W (Width)	H (Height)	D (Depth)
L30	29.00	10.88	24.50
L36	35.00	10.13	22.00
L42	41.00	10.88	24.50
L54	53.00	10.88	24.50

4" square holes for gas and electrical connections both left and right sides (rear or bottom access). Make these holes in the frame based on your requirements. 120V GFI outlet must be located within 6' of the 4" hole.

If using a countertop with overhang a 9/16" notch is required.

Use insulated jacket when installing grills in combustible material island.

INSULATED JACKET SPECIFICATIONS & INSTALLATION

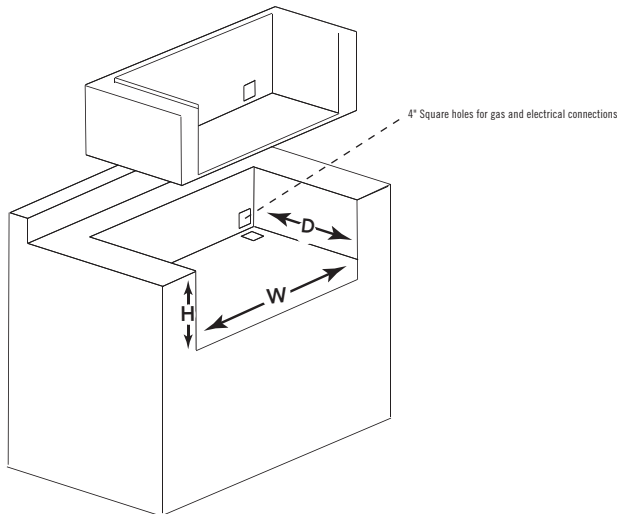

INSULATED JACKET

MODEL	W (Width)	H (Height)	D (Depth)
LIJ30	36.00	11.63	26.50
LIJ36	42.00	11.63	23.75
LIJ42	48.00	11.63	26.50
LIJ54	60.00	11.63	26.50
LIUSB2	15.50	11.63	26.50
LJPB	26.25	11.63	23.88

SPECIFICATIONS

NAPOLI OUTDOOR OVEN™ COUNTERTOP OR BUILT-IN

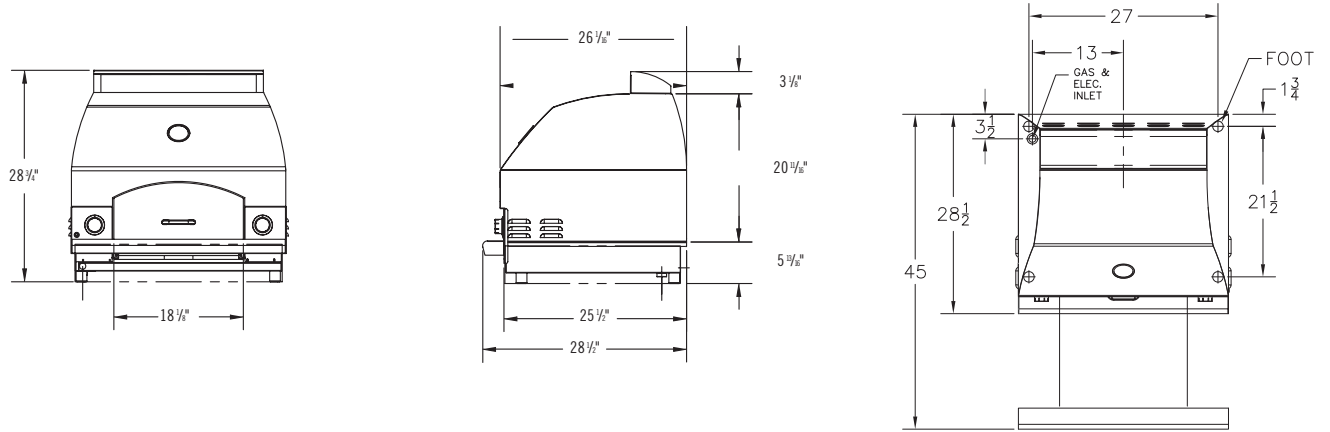

NAPOLI OUTDOOR OVEN™ FREESTANDING

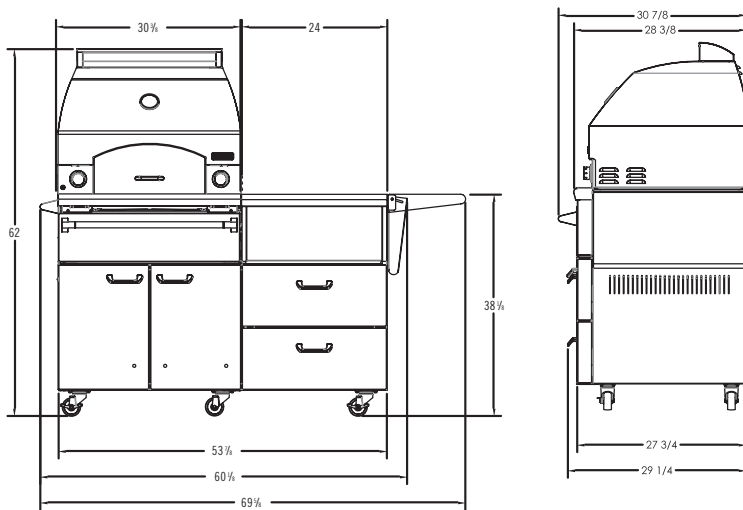

MODEL	W (Width)	H (Height)	D (Depth)
LPZA	29.00	4.00	24.50

NAPOLI OUTDOOR OVEN™ ISLAND PREPARATION

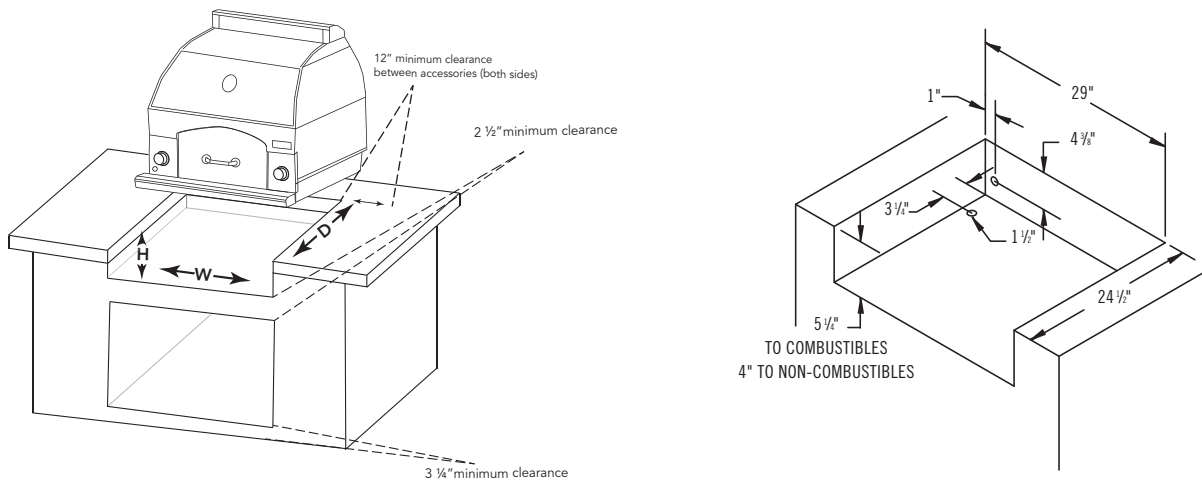

SPECIFICATIONS

ASADO COOKTOP SPECIFICATIONS & INSTALLATION

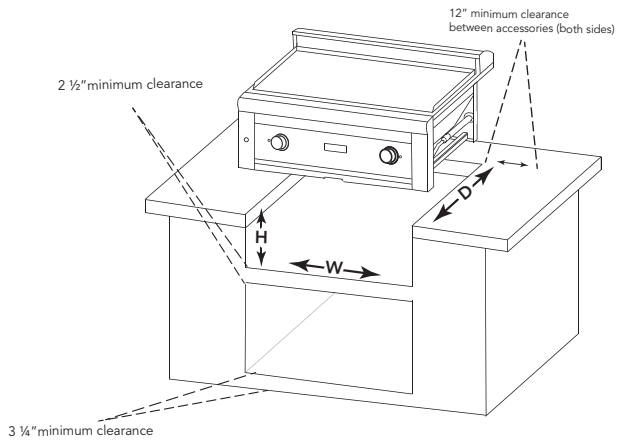

MODEL	W (Width)	H (Height)	D (Depth)
L30AG	29.00	10.88	24.50

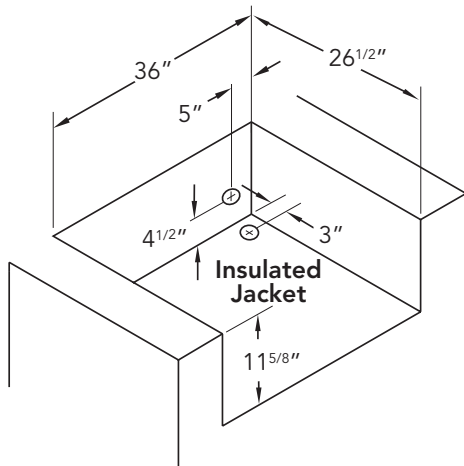
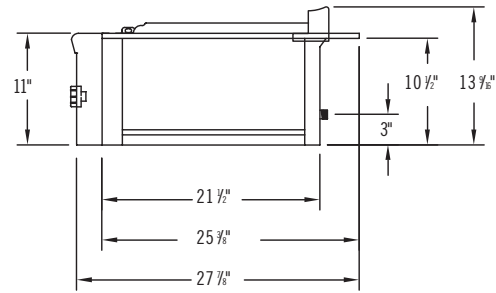
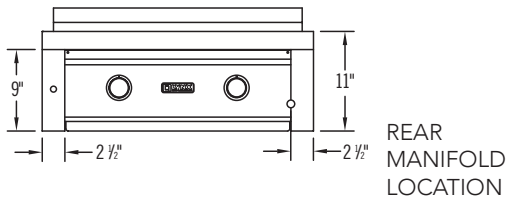

4" square holes for gas and electrical connections both left and right sides (rear or bottom access). Make these holes in the frame based on your requirements. 120V GFI outlet must be located within 6" of the 4" hole.

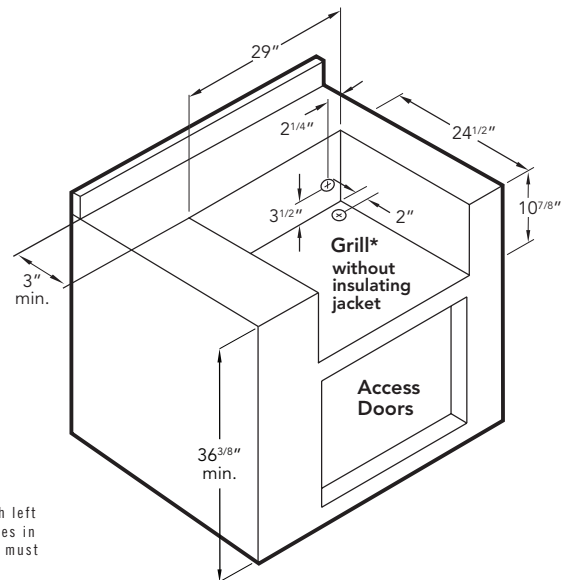

SPECIFICATIONS

SIDE BURNER SPECIFICATIONS & INSTALLATION

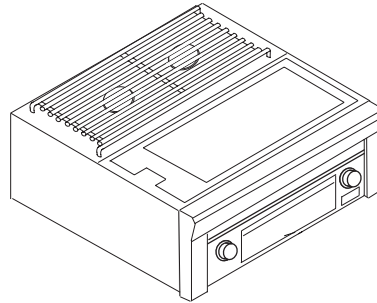
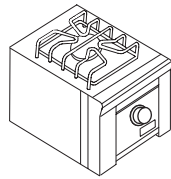
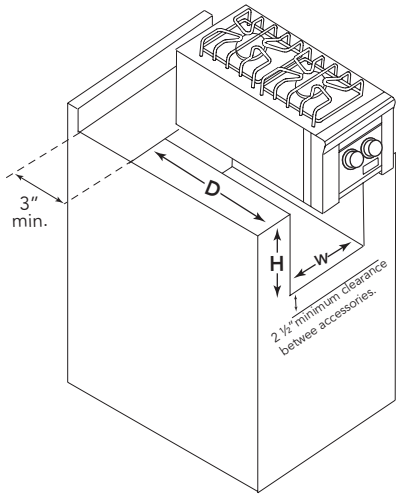

MODEL	W (Width)	H (Height)	D (Depth)
LSB1-3	12.13	10.63	12.50
LSB2-2	12.13	10.63	24.50
LSB2PC-1	24.25	10.63	24.50
LPB	19.00	10.63	22.00

WARMING DRAWERS SPECIFICATIONS & INSTALLATION

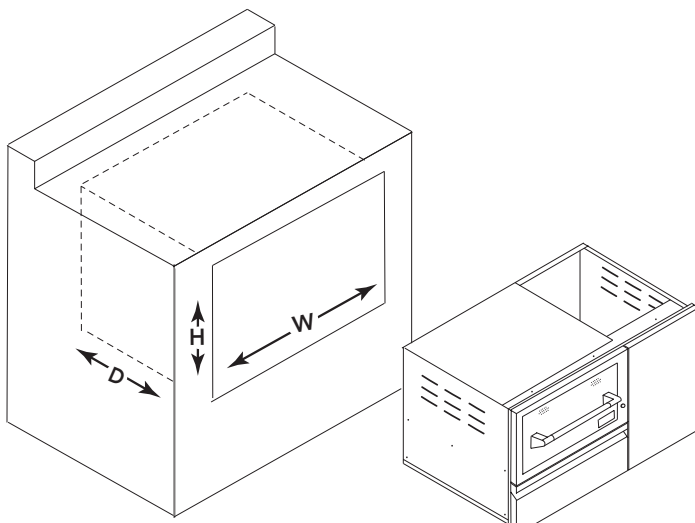

MODEL	W (Width)	H (Height)	D (Depth)
L30WD-1	28.50	10.00	20.50
L42CC-1	40.25	19.38	24.50

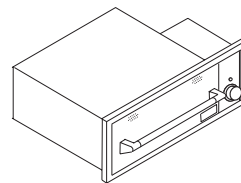

SPECIFICATIONS

COCKTAIL PROFESSIONAL SINKS SPECIFICATIONS & INSTALLATION

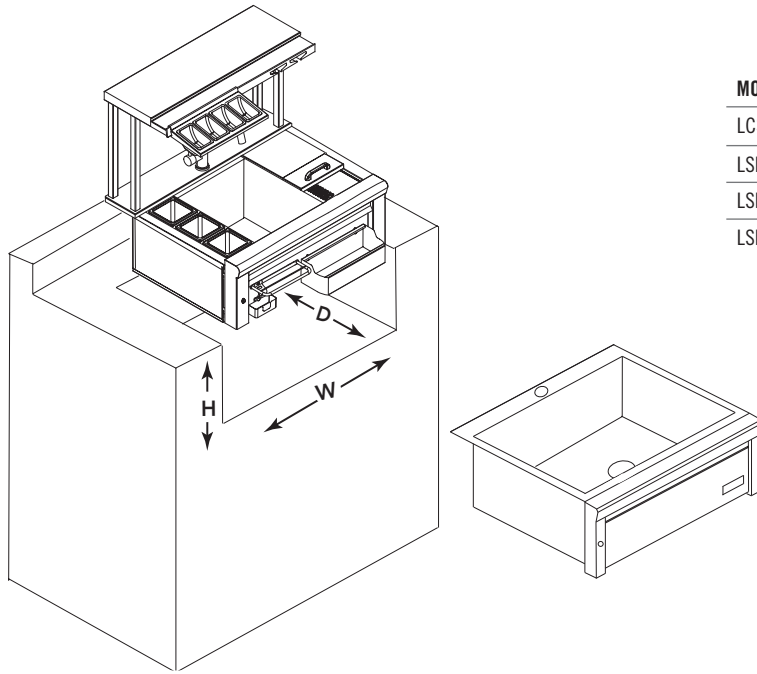

MODEL	W (Width)	H (Height)	D (Depth)
LCS30	29.00	10.50	22.00
LSK18	17.00	10.50	22.00
LSK24	23.00	10.50	22.00
LSK30	29.00	10.50	22.00

REFRIGERATION ISLAND PREPARATION

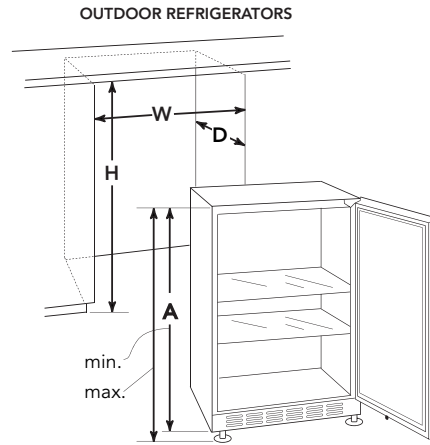
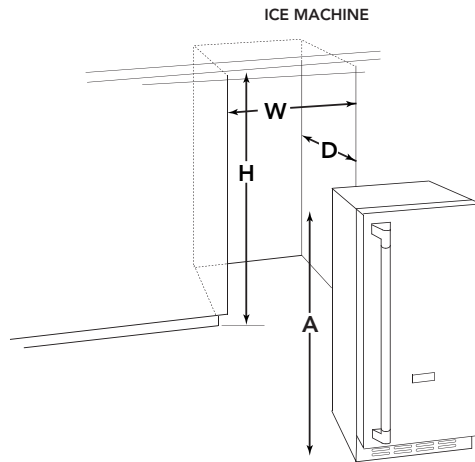

MODEL	W (Width)	H (Height)	D (Depth)	A (Adj. Height)
LN15REF	15.00	34.00-35.00	24.00	33.75-34.75
LN24REF	24.00	34.00-35.00	24.00	33.75-34.75
LM24REFC	24.00	34.00-35.00	24.00	33.75-34.75
LN24BF	24.00	34.00-35.00	24.00	33.75-34.75
LN24DWR	24.00	34.00-35.00	24.00	33.75-34.75
LN/LM15WINE	15.00	34.00-35.00	24.00	33.75-34.75
LN15ICER	15.00	34.00-35.00	24.00	33.75-34.75

SPECIFICATIONS

STORAGE

ACCESS DOORS

MODEL	W (Width)	H (Height)
LDR18L/R-4	13.38	19.00
LDR24L/R-4	19.25	19.00
LDR30T-4	25.13	19.00
LDR36T-4	31.50	19.00
LDR42T-4	37.50	19.00
LDR18L/R	13.63	19.00
LDR24L/R	19.25	19.00
LDR30T	25.25	19.00
LDR36T	31.63	19.00
LDR42T	37.63	19.00

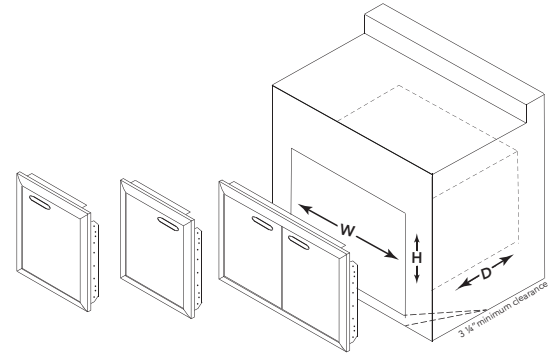

UTILITY DRAWERS

MODEL	W (Width)	H (Height)	D (Depth)
LDW16-4	12.25	19.00	24.50
LDW19-4	15.25	19.00	24.50
LMD-4	21.75	5.63	23.38
LTWL	14.63	7.25	7.00
LMD	21.75	5.63	23.38
LDW16	14.00	19.00	24.50
LDW19	17.50	19.00	24.50
LUDE	12.13	19.25	24.00
LUDXL-1	17.25	18.56	24.25

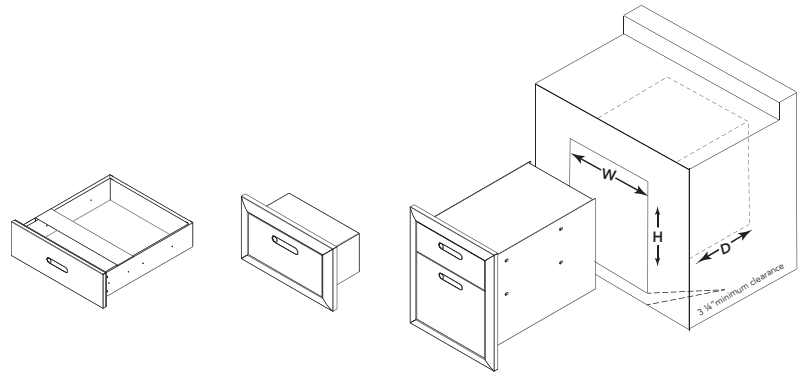

STORAGE SYSTEMS

MODEL	W (Width)	H (Height)	D (Depth)
LSA30-4	25.44	19.00	24.50
LSA36-4	31.44	19.00	24.50
LSA42-4	37.44	19.00	24.50
LPA36-4	31.50	19.00	24.50
LSA30	28.25	19.00	24.50
LSA36	34.25	19.00	24.50
LSA42	40.25	19.00	24.50
LPA36	34.25	19.00	24.50

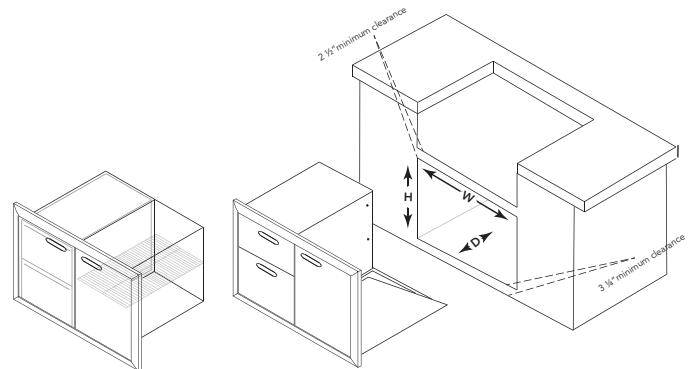

TRASH CENTERS

MODEL	W (Width)	H (Height)	D (Depth)
L20TR-4	16.13	24.00	24.50
LTA30-4	25.44	19.00	24.50
L18TS	8.25	6.25	—
LTA30	28.25	19.00	24.50
L20TR	16.81	24.00	24.75

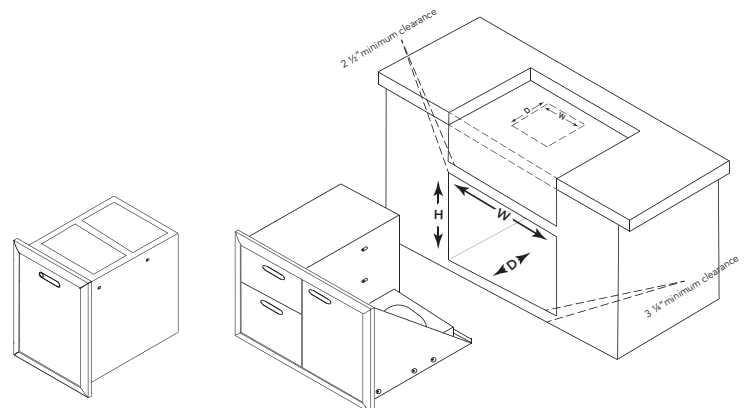

PRODUCT DIMENSION QUICK-REFERENCE GUIDE

GRILLS

MODEL	W (Width)	H (Height)	D (Depth)
L30	29.00	10.88	24.50
L36	35.00	10.13	22.00
L42	41.00	10.88	24.50
L54	53.00	10.88	24.50

SIDE BURNERS

MODEL	W (Width)	H (Height)	D (Depth)
LSB1-3	12.13	10.63	12.50
LSB2-2	12.13	10.63	24.50
LSB2PC-1	24.25	10.63	24.50
LPB	19.00	10.63	22.00

INSULATED JACKET

MODEL	W (Width)	H (Height)	D (Depth)
LJ30	36.00	11.63	26.50
LJ36	42.00	11.63	23.75
LJ42	48.00	11.63	26.50
LJ54	60.00	11.63	26.50

WARMING DRAWERS

MODEL	W (Width)	H (Height)	D (Depth)
L30WD-1	28.50	10.00	20.50
L42CC-1	40.25	19.38	24.50

NAPOLI OUTDOOR OVEN™ / ASADO COOKTOP

MODEL	W (Width)	H (Height)	D (Depth)
LPZA	29.00	4.00	24.50
L30AG	29.00	10.88	24.50

COCKTAIL PROFESSIONAL SINKS

MODEL	W (Width)	H (Height)	D (Depth)
LCS30	29.00	10.50	22.00
LSK18	17.00	10.50	22.00
LSK24	23.00	10.50	22.00
LSK30	29.00	10.50	22.00

REFRIGERATION

MODEL	W (Width)	H (Height)	D (Depth)	A (Adj. Height)
LNREF	15.00	34.00-35.00	24.00	33.75-34.75
LN24REF	24.00	34.00-35.00	24.00	33.75-34.75
LM24REFC	24.00	34.00-35.00	24.00	33.75-34.75
LN24BF	24.00	34.00-35.00	24.00	33.75-34.75
LN24DWR	24.00	34.00-35.00	24.00	33.75-34.75
LN/LMWINE	15.00	34.00-35.00	24.00	33.75-34.75
LN24ICER	15.00	34.00-35.00	24.00	33.75-34.75

PRODUCT DIMENSION QUICK-REFERENCE GUIDE

STORAGE ACCESS DOORS

MODEL	W (Width)	H (Height)
LDR18L/R-4	13.38	19.00
LDR24L/R-4	19.25	19.00
LDR30T-4	25.13	19.00
LDR36T-4	31.50	19.00
LDR42T-4	37.50	19.00
LDR18L/R	13.63	19.00
LDR24L/R	19.25	19.00
LDR30T	25.25	19.00
LDR36T	31.63	19.00
LDR42T	37.63	19.00

STORAGE SYSTEMS

MODEL	W (Width)	H (Height)	D (Depth)
LSA30-4	25.44	19.00	24.50
LSA36-4	31.44	19.00	24.50
LSA42-4	37.44	19.00	24.50
LPA36-4	31.50	19.00	24.50
LSA30	28.25	19.00	24.50
LSA36	34.25	19.00	24.50
LSA42	40.25	19.00	24.50
LPA36	34.25	19.00	24.50

STORAGE UTILITY DRAWERS

MODEL	W (Width)	H (Height)	D (Depth)
LDW16-4	12.25	19.00	24.50
LDW19-4	15.25	19.00	24.50
LMD-4	21.75	5.63	23.38
LTWL	14.63	7.25	7.00
LMD	21.75	5.63	23.38
LDW16	14.00	19.00	24.50
LDW19	17.50	19.00	24.50

TRASH CENTERS

MODEL	W (Width)	H (Height)	D (Depth)
L20TR-4	16.13	24.00	24.50
LTA30-4	25.44	19.00	24.50
L18TS	8.25	6.25	—
LTA30	28.25	19.00	24.50
L20TR	16.81	24.00	24.75

NOTE: For planning and installation details, including dimensions, specification sheets, and CAD drawings please visit the Trade Resources section of the Lynx website: MIDDLEBY.COM.MX







FOR MORE INFORMATION, PLEASE CALL 1.888.289.5969 OR VISIT WWW.LYNXGRILLS.COM
PROUDLY HANDCRAFTED AND MANUFACTURED IN THE USA

LYNX GRILLS, INC.
62201 HWY 82 WEST, GREENWOOD, MS 38930 P/N 36518 08/01/2023 ©LYNX GRILLS, INC.